

# Rosemount™ 4051S Pressure Transmitter



## Safety information

### **⚠ WARNING**

Read this document before working with the product. For personal and system safety and for optimum product performance, ensure that you thoroughly understand the contents before installing, using, and maintaining the product.

Failure to follow safe installation and servicing guidelines could result in death or serious injury.

Ensure the transmitter is installed by qualified personnel and in accordance with applicable code of practice. Use the transmitter only as specified in the product manual. Failure to do so may impair the protection provided by the transmitter.

Repair, e.g. substitution of components, etc. may jeopardize safety and is under no circumstances allowed. Unauthorized changes to the product are strictly prohibited, as they may unintentionally and unpredictably alter performance and jeopardize safety. Unauthorized changes that interfere with the integrity of the welds or flanges, such as making additional perforations, compromise product integrity and safety. Equipment ratings and certifications are no longer valid on any products that have been damaged or modified without the prior written permission of Emerson. Any continued use of product that has been damaged or modified without the written authorization is at the customer's sole risk and expense.

#### **Explosions**

Explosions could result in death or serious injury.

In an explosion-proof/flameproof installation, do not remove the transmitter covers when power is applied to the transmitter. Installation of this transmitter must be in accordance with the appropriate local, national, and international standards, codes, and practices. Review the hazardous locations certifications in the [Rosemount 4051S Pressure Transmitters Quick Start Guide](#) for any restrictions associated with a safe installation. Before connecting a field communicator in an explosive atmosphere, ensure that the instruments are installed in accordance with intrinsically safe or non-incendive field wiring practices.

#### **Process leaks**

Process leaks may cause harm or result in death.

Install and tighten process connectors before applying pressure. Do not remove while in operation.

#### **Electrical shock**

Electrical shock can result in death or serious injury.

Avoid contact with the leads and terminals. High voltage that may be present on leads can cause electrical shock. Ensure the power to the transmitter is off and the lines to any other external power source are disconnected or not powered while wiring the transmitter. Ensure the wiring is suitable for the electrical current and the insulation is suitable for the voltage, temperature, and environment.

#### **Replacement equipment**

The use of replacement equipment or spare parts not approved by Emerson may reduce the pressure retention or other safety capabilities of the transmitter and may lead to dangerous or unsafe conditions.

Use only bolts, replacement equipment, or other spare parts supplied or approved by Emerson.

When cover is removed, protect the interior of the transmitter from external contamination exceeding that of a Pollution Degree 2 environment.

---

## **⚠ WARNING**

### **Physical access**

Unauthorized personnel may potentially cause significant damage to and/or misconfiguration of end users' equipment. This could be intentional or unintentional and needs to be protected against.

Physical security is an important part of any security program and fundamental in protecting your system. Restrict physical access by unauthorized personnel to protect end users' assets. This is true for all systems used within the facility.

---



# Contents

<b>Chapter 1</b>	<b>Introduction.....</b>	<b>7</b>
	1.1 Models covered.....	7
	1.2 Product recycling/disposal.....	7
	1.3 Related product training.....	7
<b>Chapter 2</b>	<b>Configuration.....</b>	<b>9</b>
	2.1 Configuration overview.....	9
	2.2 System readiness.....	9
	2.3 Configuration tools.....	9
	2.4 How to configure.....	11
	2.5 Application specific configuration.....	16
	2.6 Detailed transmitter setup.....	24
	2.7 Configure using Bluetooth® wireless technology.....	28
	2.8 Diagnostics overview.....	28
	2.9 Performing transmitter tests.....	39
	2.10 Configuring Burst mode.....	40
	2.11 Using <b>High Speed Sensor Response Time</b> (option P6).....	41
<b>Chapter 3</b>	<b>Hardware installation.....</b>	<b>43</b>
	3.1 Overview.....	43
	3.2 Considerations.....	43
	3.3 Installation procedures.....	45
<b>Chapter 4</b>	<b>Electrical installation.....</b>	<b>69</b>
	4.1 Overview.....	69
	4.2 Install LCD display.....	69
	4.3 Configuring transmitter security.....	70
	4.4 Move <b>Alarm</b> switch.....	72
	4.5 Electrical considerations.....	74
<b>Chapter 5</b>	<b>Relay switches (Transmitter output code S).....</b>	<b>83</b>
	5.1 Relay terminal block components.....	83
	5.2 How relay switches work.....	84
	5.3 Relay wiring.....	85
	5.4 Relay power.....	87
	5.5 Relay configuration.....	88
	5.6 Commissioning a transmitter with relay switches.....	89
	5.7 Relay switch operation examples.....	89
	5.8 Relay tests.....	90
	5.9 Relay diagnostics.....	90
<b>Chapter 6</b>	<b>Operation and maintenance.....</b>	<b>91</b>
	6.1 Overview.....	91
	6.2 Recommended calibration tasks.....	91
	6.3 Calibration overview.....	92

	6.4 Trimming pressure signal.....	95
	6.5 Trimming the analog output.....	97
	6.6 Relay maintenance and operation (with output protocol code S).....	99
<b>Chapter 7</b>	<b>Troubleshooting.....</b>	<b>101</b>
	7.1 Troubleshooting overview.....	101
	7.2 Diagnostic messages.....	101
	7.3 Disassembling the transmitter.....	107
	7.4 Reassembly procedures.....	109
<b>Chapter 8</b>	<b>Safety Instrumented Systems (SIS).....</b>	<b>113</b>
	8.1 Rosemount 4051S safety certified identification.....	113
	8.2 Installation in Safety Instrumented Systems (SIS) applications.....	113
	8.3 Configuring in Safety Instrumented Systems (SIS) applications.....	114
	8.4 <b>Damping</b> .....	114
	8.5 Alarm and saturation levels.....	114
	8.6 Safety Instrumented Systems (SIS) operation and maintenance.....	115
	8.7 Inspection.....	117
<b>Appendix A</b>	<b>Reference data.....</b>	<b>119</b>
	A.1 Ordering information, specifications, and drawings.....	119
	A.2 Product Certifications.....	119
<b>Appendix B</b>	<b>Device Driver (DD) menu trees.....</b>	<b>121</b>
<b>Appendix C</b>	<b>Quick Service buttons.....</b>	<b>131</b>

# 1 Introduction

## 1.1 Models covered

The following Rosemount 4051S Transmitters are covered by this manual:

- Rosemount 4051S Coplanar™ Pressure Transmitter
  - Measures differential and gauge pressure up to 2,000 psi (137.9 bar).
  - Measures absolute pressure up to 4,000 psia (275.8 bar).
- Rosemount 4051S In-Line Pressure Transmitter
  - Measures gauge pressure up to 10,000 psig (689.5 barg) and absolute pressure up to 10,000 psia (689.5 bar).
- Rosemount 4051SLT Level Transmitter
  - Measures level up to 300 psi (20.7 bar).
- Rosemount 4051SF Differential Pressure (DP) Flow Meters
  - Measures flow in line sizes from ½ to 96 in. (13 to 2,438 mm).

## 1.2 Product recycling/disposal

Consider recycling equipment and packaging.

Dispose of the product and packaging in accordance with local and national legislation/regulations.

## 1.3 Related product training

To ensure that your training efforts continually evolve with technology, Emerson offers a broad portfolio of different solutions and delivery methods that can be easily adapted to help meet your business needs. Our scalable, customizable training packages let you match the right training solutions to your operational needs and budget.

To learn more, visit [Emerson Training](#).

For the best user experience, log into [MyEmerson.com](#).



## 2 Configuration

### 2.1 Configuration overview

This section provides instructions for tasks that must be performed prior to device installation, during commissioning, and after installation.

Instructions for configuration by the following methods are included:

- Communication device, such as AMS Trex™ Device Communicator
- HART® host, such as AMS Device Manager
- AMS Device Configurator Bluetooth® app
- **Quick Service** buttons

### 2.2 System readiness

If using HART®-based control or asset management systems, confirm the HART capability of such systems prior to commissioning and installation. Not all systems can communicate with HART Revision 7 devices.

#### 2.2.1 Confirming correct device driver

- Verify that the latest device driver (DD/DTM™) is loaded on your systems to ensure proper communications.
- Download the latest DD at [Software & Drivers](#) or [FieldCommGroup.org](#).

#### 2.2.2 Device revision history

See *NAMUR NE-53 Device Revision History* at [NAMUR NE-53 Documentation for Measurement Instruments](#) for more details on device revisions and files.

### 2.3 Configuration tools

Set up the transmitter before or after mounting it by wiring it to a power supply and a configuration device as shown in [Figure 2-1](#).

Configure the transmitter either before or after installation. To ensure that all transmitter components are in working order prior to installation, configure the transmitter on the bench using the applicable communication device and power supply.

See [Figure 2-1](#) for more information on how to wire the power supply and attach leads from a communication device.

Figure 2-1: Power Supply and Communicator Wiring

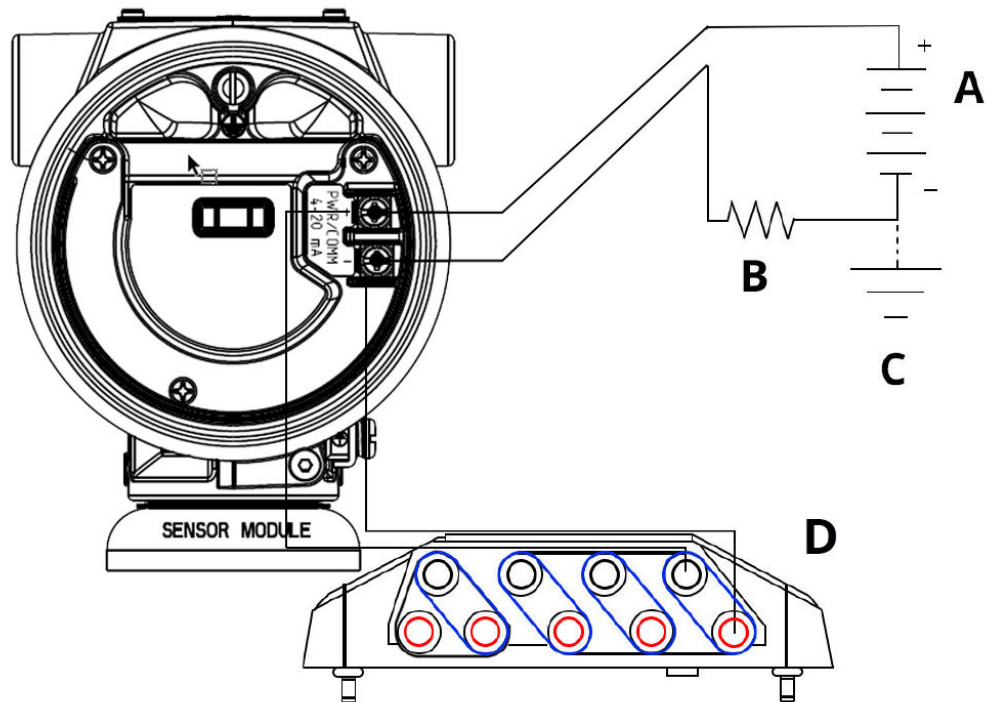

- A. Power supply
- B. Resistor
- C. Ground
- D. Communicator wiring

**Note**

You do not need the resistor if you are connected in one of the following ways:

- AMS Trex™ Device Communicator (HART + power)
- AMS Device Configurator Bluetooth® app
- **Quick Service** buttons

Table 2-1: Power Supply and Resistance by Communicator Type

Communicator	Power supply	Resistor
AMS Device Manager	≥ 17.4 Vdc	≥ 250 Ω
AMS Trex (HART®)	≥ 17.4 Vdc	≥ 250 Ω
AMS Trex (HART + power)	None	None
AMS Device Configurator Bluetooth app	11.5 Vdc	None
<b>Quick Service</b> buttons	11.5 Vdc	None

### 2.3.1 Configuring using a communication device

For more detailed information about AMS Trex, see [AMS Trex Device Communicator](#).

It is critical that the latest device drivers (DDs) are loaded onto the communication device to ensure full functionality.

### 2.3.2 Configuring using AMS Device Manager

For more detailed information about AMS Device Manager, see [AMS Device Manager](#).

It is critical that the latest device drivers (DDs) are loaded onto the AMS Device Manager to ensure full functionality.

### 2.3.3 Configuring using AMS Device Configurator Bluetooth® app

#### Related information

[Configure using Bluetooth wireless technology](#)

### 2.3.4 Configuring using the Quick Service buttons

You can use the **Quick Service** buttons for the following configuration and maintenance tasks:

- **View Configuration**
- **Zero**
- **Rerange**
- **Loop Test**
- **Rotate Display**

---

#### Note

Physical buttons are fixed on the display, regardless of the display orientation. Follow the screen labels for proper button operation.

To use the buttons, remove the transmitter display cover and follow the onscreen prompts to complete the desired task.

---

## 2.4 How to configure

Each unique application of the Rosemount 4051S may require different steps to commission and configure the transmitter.

This section provides an overview of the procedures to perform common configuration tasks on your transmitter.

### NOTICE

If either the hardware **Security** switch or the software **Security** setting is On, it is not possible to configure the transmitter.

---

## 2.4.1 Setting the loop to Manual

Before sending or requesting data that would disrupt the loop or change the output of the transmitter, set the process application loop to Manual control.

### NOTICE

The configuration device will prompt you to set the loop to Manual when necessary. The prompt is only a reminder; acknowledging this prompt does not set the loop to Manual. You must set the loop to Manual control as a separate operation.

## 2.4.2 Verifying configuration parameters

Emerson recommends verifying the following configuration parameters prior to installation into the process:

- **Alarm and Saturation Values**
- **Damping**
- **Process Variables**
- **Range Values**
- **Tag**
- **Transfer Function**
- **Units**

### Verify configuration parameters using a communication device

#### Procedure

1. Go to **Device Settings** → **Setup Overview** → **Alarm and Saturation Values** to set alarm and saturation levels.
2. Go to **Device Settings** → **Setup Overview** → **Output** to set damping.
3. Set the process variables.
  - a) To set the primary variable (PV), go to **Device Settings** → **Output** → **Analog Output** → **PV Setup**.
  - b) To set up the other process variables, go to **Device Settings** → **Communication** → **HART** → **Variable Mapping**.
4. To set range values, go to **Device Settings** → **Output** → **Analog Output** → **PV Setup**.
5. To set up a tag, go to **Device Settings** → **Setup Overview** → **Device**.
6. To set transfer function, go to **Device Settings** → **Output** → **Analog Output** → **PV Setup**.
7. Set units.
  - a) To set pressure units, go to **Device Settings** → **Output** → **Pressure** → **Setup**.
  - b) To set other units, go to **Device Settings** → **Output** → **Pressure/Flow/Totalizer/Level/Volume/Module Temperature** → **Setup**.

## 2.4.3 Setting Pressure Unit

The **Pressure Unit** command sets the unit of measure for the reported pressure.

The procedure is the same for other variables:

- **Flow**
- **Totalizer**
- **Level**
- **Volume**
- **Module Temperature**

Select your desired variable and then set the unit using the desired variable in place of **Pressure**.

### Set Pressure Unit using a communication device

#### Procedure

Go to **Device Settings** → **Output** → **Pressure** → **Setup**.

## 2.4.4 Setting transmitter output (transfer function)

The transmitter has two output settings: Linear and Square Root.

As shown in [Figure 2-2](#), activating the Square Root option makes analog output proportional to flow and includes a fixed Low Flow Cut-off at four percent and a Low Flow Cut-in of five percent of the square root analog output range.

Emerson recommends using application-specific configuration to configure differential pressure (DP) flow and DP level applications. When either flow rate or level is assigned to the primary variable, the transfer function will be set to Linear in the communication device and cannot be changed to Square Root. For flow rate specifically, the flow rate variable is automatically set to a Square Root relationship with respect to pressure.

Figure 2-2: 4-20 mA HART® Square Root Output Transition Point (Example)

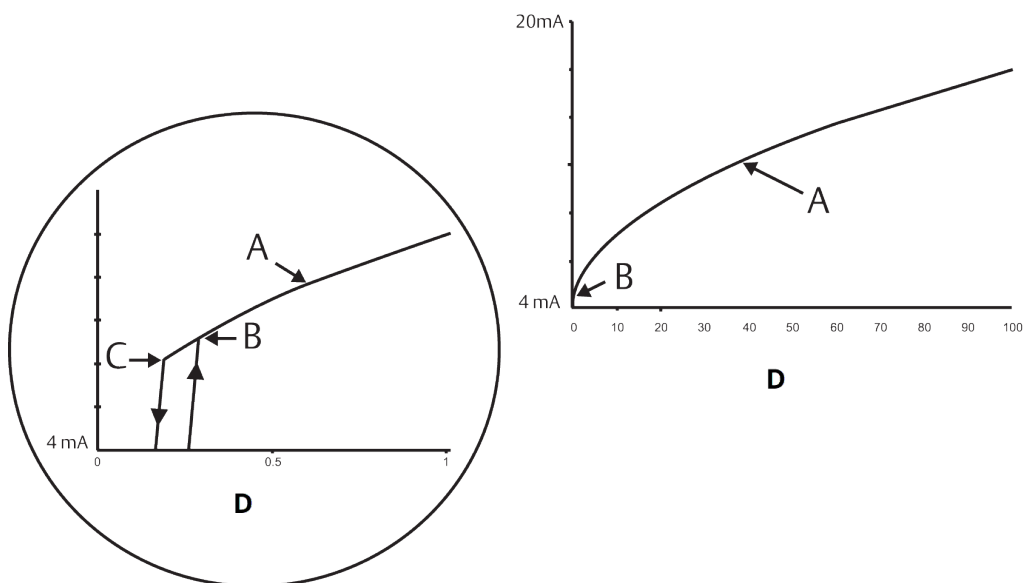

- A. Square root curve
- B. 5 percent transition point
- C. 4 percent transition point
- D. Percent pressure input

#### Related information

[Application specific configuration](#)

### Set transmitter output using a communication device

#### Procedure

Go to **Device Settings** → **Output** → **Analog Output** → **PV Setup** → **Transfer Function**.

## 2.4.5 Rerange the transmitter

The **Range Values** command sets each of the lower and upper range analog values (4 and 20 mA points) to a pressure.

The lower range point represents 0 percent of range, and the upper range point represents 100 percent of range. In practice, the transmitter range values may be changed as often as necessary to reflect changing process requirements.

Select from one of the methods below to rerange the transmitter. Each method is unique; examine all options closely before deciding which method works best for your process.

- Rerange by manually setting range points.
- Rerange with a pressure input source.

### Rerange the transmitter using a communication device

#### Procedure

1. Go to **Device Settings** → **Output** → **Analog Output** → **PV Setup**.

2. Do one of the following:
  - Enter range points.
  - Select **Range by Applying Pressure** and follow the prompts.

## 2.4.6 Damping

The **Damping** command changes the response time of the transmitter; higher values can smooth variations in output readings caused by rapid input changes.

Determine the appropriate **Damping** setting based on the necessary response time, signal stability, and other requirements of the loop dynamics within your system. The **Damping** command uses floating point configuration, allowing you to input any damping value within 0 - 60 seconds.

### Damping using a communication device

#### Procedure

Go to **Device Settings** → **Output** → [pick the output you want to set damping for (such as **Pressure or Level**)] → **Setup** → **Damping**.

## 2.4.7 Configuring the display

### Configuring the graphical LCD display

Customize the graphical LCD display to suit application requirements.

The display will always show the primary variable (PV) and alternate between the selected items on the secondary portion of the screen.

- Pressure
- Module Temperature
- Percent of Range
- Level
- Volume
- Flow Rate
- Totalized Flow
- HART® Long Tag
- Alarm Switch State
- Security Status
- Loop Current
- Bluetooth® Status
- Standard Deviation
- Coefficient of Variation
- Relay 1 State
- Relay 2 State

You can use software to rotate the graphical LCD display in 90-degree increments to accommodate various transmitter orientations.

### Advanced display settings

You can configure additional settings for the graphical LCD display from the **Advanced display settings** tab.

- Select from seven different languages:
  - English
  - Chinese
  - French
  - German
  - Italian
  - Portuguese
  - Spanish
- Define the type of decimal separator used: comma or period.
- For gauge and absolute transmitters, you can enable a Gauge Pressure (GP) or Absolute Pressure (AP) unit label. For example, if units are psi and the GP/AP unit label is enabled, then the units will display as `psi-g` or `psi-a` on the graphical display.
- Turn the back-light either on or off.
- Adjust the number of decimal places on the display up one or down one from the default.

### Configure graphical LCD display using a communication device

#### Procedure

Go to **Device Settings** → **Display** → **Display** → **Additional Parameters**.

## 2.5 Application specific configuration

### 2.5.1 Configuring for flow rate

With the flow rate configuration, you can create a relationship between the pressure units and user-defined flow units. By defining a pressure at a specific flow rate, the transmitter will perform a square root extraction to convert the pressure reading to a linear flow rate output.

Flow rate configuration includes the following parameters:

<b>Flow Units</b>	User-specified units for flow rate
<b>Entered Flow Rate</b>	User-specified flow rate
<b>Pressure at Flow Rate</b>	User-specified pressure at the entered flow rate <sup>(1)</sup>

### Configure for flow rate using a communication device

#### Procedure

Go to **Device Settings** → **Output** → **Flow** → **Setup** → **Configure Flow**.

---

(1) You can use the [DP Flow Sizing and Selection Tool](#) to help you establish the relationship between pressure and flow.

## Configuring Low Flow Cut-off

Emerson highly recommends using the **Low Flow Cut-off** function to have a stable output and avoid problems due to process noise at a low flow or no flow condition.

There are two key definitions to aid in understanding **Low Flow Cut-off**:

- Pressure cut-off value** The pressure at which the field device will stop measuring the flow rate. If the measured pressure is less than the pressure cut-off value, the device will calculate the flow rate to be zero.
- Pressure cut-in value** The pressure at which the field device will begin measuring the flow rate. If the measured pressure is more than the cut-in value, the device will begin measuring flow rate.

## Configure Low Flow Cut-off using a communication device

### Procedure

Go to **Device Settings** → **Output** → **Flow** → **Setup** → **Low Flow Cut-off**.

## Configuring for flow rate example

Use a differential pressure transmitter in conjunction with an orifice plate in a water flow application where the full-scale flow rate is 20,000 US gallons per hour with a differential pressure of 100 inH<sub>2</sub>O at 68 °F. The pressure cut-off and pressure cut-in values for the **Low Flow Cut-off** will be set to 0.5 inH<sub>2</sub>O at 68 °F.

Based on this information, the configuration would be:

**Table 2-2: Entered Values for Flow Rate Configuration Example**

Parameter	Value
<b>Flow Rate Units</b>	USGPH
<b>Entered Flow Rate</b>	20,000 USGPH
<b>Pressure at Flow Rate</b>	100 inH <sub>2</sub> O at 68 °F
<b>Low Flow Cut-off</b>	Cut-off mode: On
<b>Pressure Cut-off Value</b>	0.5 inH <sub>2</sub> O at 68 °F
<b>Pressure Cut-in Value</b>	0.5 inH <sub>2</sub> O at 68 °F

Figure 2-3: AMS Configuration Screen for *Flow Rate* Example

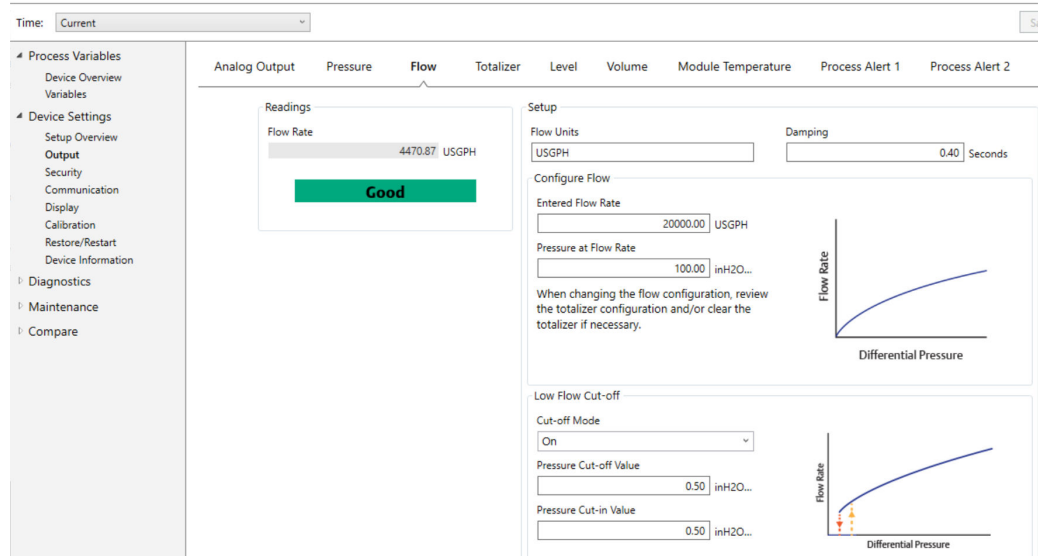

## 2.5.2 Configuring for totalized flow

The flow totalizer will track the amount of flow that has passed your measurement point over time. The totalized flow output tracks the configured flow rate and will require the following inputs:

**Totalizer Unit** Unit of measure associated with the mass or volume component of the flow rate. Six characters maximum.

**Flow Unit of Time** Unit of measure associated with the time component of the flow rate.

### Example

For a **Flow Rate** of USGPH, the **Totalizer Unit** would be USGAL, and the **Flow Unit of Time** would be Hours.

The flow unit is displayed on the communication device for convenience when you configure totalized flow on a communication device.

### Direction

The totalizer can be configured to support the following flow orientations:

**Forward Flow** Only tracks flow in the forward direction (positive differential pressure).

**Reverse Flow** Only tracks flow in the reverse direction (negative differential pressure).

**Gross Flow** Gross Flow = Forward Flow + Reverse Flow

**Net Flow** Net Flow = Forward Flow - Reverse Flow

### Max Value

The maximum value that the totalizer can measure is displayed.

### Unit Conversion Factor

Used to define a totalizer specific unit of measure.

**Example** If the unit you input is USGPH, and your desired totalizer value is thousands of USGAL, MUSGAL, a conversion factor of 0.001 would convert USGAL to MUSGAL. If your desired totalizer value is USGAL, use a **Unit Conversion Factor** of 1.

## Configure for Totalized Flow using a communication device

### Procedure

1. Go to **Device Settings** → **Output** → **Totalizer** → **Setup**.

**Figure 2-4: AMS Configuration Screen for Flow Totalizer Example**

2. Once the totalizer is configured and you are ready to begin totalizing, do the following:
  - a) Go to **Device Settings** → **Output** → **Totalizer** → **Control**.
  - b) Set the **Totalizer Mode** value to Stopped.
  - c) Run the **Clear Totalizer** method.
  - d) Set the **Totalizer Mode** value to Totalizing.

### Note

If either the hardware **Security** switch or the software **Security** setting is On, it is not possible to clear the totalizer.

## 2.5.3 Configuring for level

With level configuration, you can convert your pressure transmitter to output in level units by creating a relationship between the measured pressure units and the desired level units.

To define this relationship directly, enter the maximum pressure at the maximum level and the minimum pressure at the minimum level.

To simplify configuration and to capture the unique applications that are associated with level measurement, Emerson recommends using the built-in level configurator to quickly and easily configure the transmitter to measure level.

## Level configuration parameters

The level configurator calculates the relationship between pressure and level using the following parameters:

<b>Level Units</b>	User-selectable units for level measurement
<b>Tank Configuration</b>	Vented or pressurized tank
<b>Technology</b>	Selection is dependent on tank configuration. <ul style="list-style-type: none"> <li>• Capillary Remote Seal(s)</li> <li>• Direct Mount</li> <li>• Impulse Piping (wet or dry leg)</li> </ul>
<b>Maximum Level</b>	Maximum level that can be measured
<b>Minimum Level</b>	Minimum level that can be measured
<b>Process Fluid Specific Gravity</b>	Specific gravity of the process fluid

If applicable:

<b>Pressure Tap Configuration</b>	Vertical distance between high side process connection and transmitter
<b>Fill Fluid</b>	Fill fluid used with remote seal capillary system
<b>Wet Leg</b>	Height of low pressure wet leg
<b>Wet Leg Specific Gravity</b>	Specific gravity of the wet leg

## Configure for level

### Procedure

Go to **Device Settings** → **Output** → **Level** → **Level Configurator**.

## Adjust Level Reading

After configuring level, you can use adjust level reading to change the transmitter level reading to match a desired level. The transmitter can use this adjustment to eliminate the effects of various installation variables, such as ambient temperature effects or distance measurement errors.

### Procedure

Go to **Device Settings** → **Output** → **Level** → **Calibration** → **Adjust Level Reading**.

## Configure for level example

Use a differential pressure Rosemount 4051S with two remote seals on a pressurized tank installation where it will measure level.

The tank has a direct mount seal transmitter on the high side and a low side remote seal with capillary connection with silicone 200 fill fluid. The process fluid is water with a specific gravity of 1. The transmitter is mounted on the lower tap, which is defined as zero level, and the low-side seal is mounted 10 feet above. The **Level Configurator** method in AMS Device Manager walks you through the configuration to establish the pressure at both minimum and maximum level.

**Figure 2-5: Level Configurator unit information Screen**

Level Configurator

Select the following unit information:

Feet

?

Next Cancel

**Figure 2-6: Level Configurator tank configuration Screen**

Level Configurator

Select the tank configuration:

Pressurized Tank (dual process connection)

?

Next Cancel

**Figure 2-7: Level Configurator technology Screen**

Level Configurator

Select the technology:

Capillary System

?

Next Cancel

Figure 2-8: Level Configurator Water Return Screen

**Level Configurator**

Enter the required information:

Maximum Level (L2)  
 Feet

Minimum Level (L1)  
 Feet

Process Fluid Specific Gravity

Set Vertical Distance Between Process Connections:

Vertical Distance (D1)  
 Feet

Fill Fluid

Next Cancel

After you complete the Level Configurator method, you can view the **Level Output** screen to confirm that the values are set as expected.

Figure 2-9: Level/Output Screen

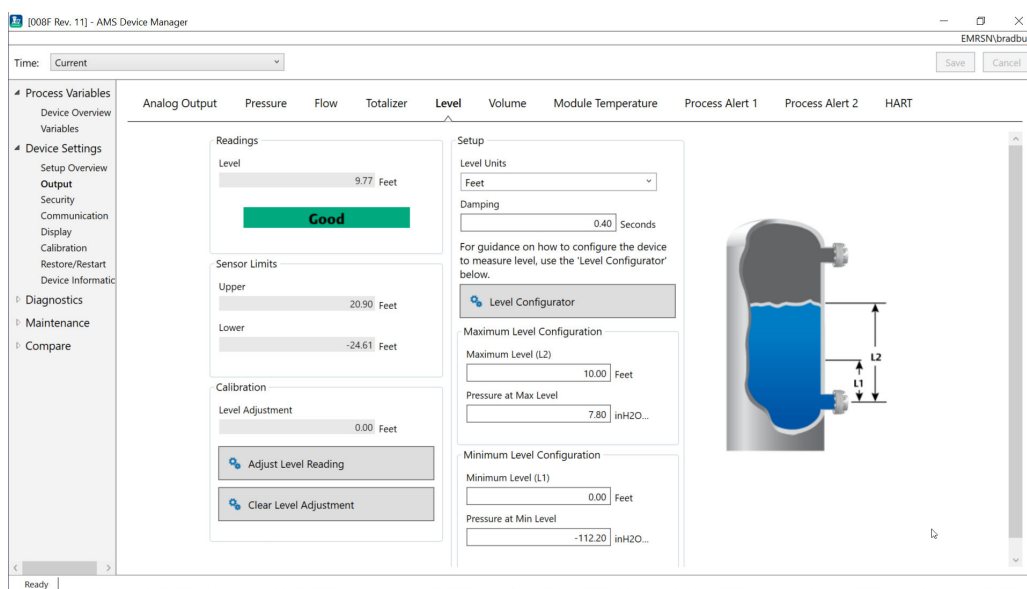

You can use the **Adjust Level Reading** button to adjust the level reading based on the transmitter sensor limit. In this example, the **Upper Sensor Limit** is 20.9 feet, and the **Lower Sensor Limit** is -24.61 feet. Therefore, the maximum adjustment that can be made is calculated by taking  $(20.9 - (-24.61)) * 0.03 = 1.37$  feet.

Therefore, you could adjust the level up to 11.14 feet maximum or down to 8.4 feet minimum from its current value of 9.77 feet. To adjust further, you would need to manually update the **Minimum Level Configuration** and/or **Maximum Level Configuration** to correct the output to the desired value.

## 2.5.4 Configuring for volume

You can configure for volume to track the relationship between level in a tank and respective volume.

This method allows you to select from one of five standard tank geometries or to configure the device with a strapping table to create a relationship between level and volume.

### Volume configuration parameters

You can configure volume to use any one of five standard tank geometries to calculate volume as a function of level.

Standard tank geometries assume that zero level is at the geometric bottom of the tank to accurately calculate the volume of the entire tank. If your zero level point is above the geometric bottom of the tank, you can correct your volume reading in one of the following ways:

- Adjust the level reading on the **Level Configuration** window.
- Use a strapping table to configure the level and volume relationship.

The **Configure Tank** method creates a relationship between level and volume using the following parameters:

**Tank type**      User-selectable tank geometry

- Sphere
- Vertical bullet
- Horizontal bullet
- Vertical cylinder
- Horizontal cylinder
- Custom

**Volume units** User-selectable units for volume measurement

**Level units** User-selectable units for level measurement. Level unit selection changes in this method will update the level output.

**Tank length (L)** Length of the tank, not required for a sphere or custom tank type

**Tank radius (R)** Radius of the tank, not required for custom tank type

#### Parameters for custom tank type

**Number of strapping points** Number of user-entered points to relate level to volume. 2 minimum and 50 maximum.

**Level and volume** For each strapping point, enter a level and volume.

### NOTICE

Values for **Level** and **Volume** must be greater than or equal to zero. Entries for each strapping point must have consistently increasing or decreasing values for both **Level** and **Volume** and must not exceed the maximum or minimum range limit of the dynamic process variable, respectively.

Levels below the **Level** entry on **Strapping Point 1** will output the volume on **Strapping Point 1**. Levels above the highest level on the strapping table will output the highest volume entered. In either case, the **Volume** reading will show a Degraded status to alert you of the problem.

## Configure for volume using a communication device

### Procedure

Go to **Device Settings** → **Output** → **Volume** → **Setup** → **Configure Tank**.

## 2.6 Detailed transmitter setup

### 2.6.1 Configuring Alarm and Saturation Values

In normal operation, the transmitter drives the output in response to pressure from the lower and upper trim points. If the pressure goes outside of the sensor limits, or if the output would be beyond the saturation points, the output will be limited to the associated saturation point.

The Rosemount 4051S Transmitter automatically and continuously performs self-diagnostic routines. If the self-diagnostic routines detect a failure, the transmitter drives the output to configured alarm value based on the position of the **Alarm** switch.

**Table 2-3: Rosemount Alarm and Saturation Values**

Level	4-20 mA saturation	4-20 mA alarm
Low	3.9 mA	≤ 3.725 mA
High	20.8 mA	> 22.5 mA

**Table 2-4: NAMUR-Compliant Alarm and Saturation Values**

Level	4-20 mA saturation	4-20 mA alarm
Low	3.8 mA	≤ 3.575 mA
High	20.5 mA	> 22.5 mA

**Table 2-5: Custom Alarm and Saturation Values**

Level	4-20 mA saturation	4-20 mA alarm
Low	3.67 - 3.90 mA	3.57 - 3.80 mA
High	20.1 - 22.9 mA	20.2 - 23.0 mA

- Low alarm level must be at least 0.1 mA less than the low saturation level.
- High alarm level must be at least 0.1 mA higher than the high saturation level.

**Related information**

[Move Alarm switch](#)

**Configure Alarm and Saturation Values using a communication device**

**Procedure**

Go to **Device Settings** → **Setup Overview** → **Alarm and Saturation Values** → **Configure Alarm and Saturation Values**.

**2.6.2 Configuring process alerts**

There are two process alerts that you can configure to use with any dynamic process variable.

Dynamic process variables:

- **Pressure**
- **Flow Rate**
- **Totalizer**
- **Level**
- **Volume**
- **Module Temperature**

The process alerts are independent of each other.

You can use these alerts to receive notifications via HART® **Status Alert** or via **Analog Output Alarm** and/or to control the optional relay switches. Process alerts can be triggered with any dynamic variable, regardless of the HART variable assignments. This means that an **Analog Output Alarm** or the optional relay switches can be triggered by any of the

dynamic process variables listed above, even if they are not assigned to be the HART primary variable.

## Process alert configuration parameters

Use the **Configure Process Alert** method to configure each process alert. You can configure the following parameters:

### Notification Mode

Sets the method of notification or disables the process alert.

- Disable Alert
- HART® Status Alert
- Analog Output Alarm
- Relay and HART Status Alert
- Relay and Analog Output Alarm

---

### Note

Relay and HART Status Alert and Relay and Analog Output Alarm will only be available if relay switches are included on the transmitter. Additional configuration steps will also be needed to fully set up the relays.

---

### Monitored Device Variable

The dynamic variable that the process alert tracks.

- Pressure
- Flow Rate
- Totalizer
- Level
- Volume
- Module Temperature

### Activation Trigger

Activates the process alert when the dynamic variable is one of the following:

- Above High Side
- Below Low Side
- Inside Window
- Outside Window

### High Alert Value

When the **Monitored Device Variable** crosses this high threshold, the process alert will take the configured action. (Not used for Below Low Side activation trigger).

### Low Alert Value

When the **Monitored Device Variable** value crosses this low threshold, the process alert will take the configured action. (Not used for Above High Side activation trigger).

### Sporadic Alert Reduction

Two different approaches to prevent repeated activation or deactivation of the process alert when the dynamic process variable is fluctuating near one of the alert thresholds.

**Deadband** A user-defined range, entered in the same units as the **Monitored Device Variable**, beyond the **Alert Value** trigger when a process alert will not be enunciated.

**Time Delay** A user-defined amount of time (30 seconds maximum) after alert detection when the process alert will not be enunciated.

#### Alert Name

The name that will be shown for the alert on the device display.

### NOTICE

The **High Alert Value** must be higher than the **Low Alert Value**. Both alert values must be within the range limits of the dynamic process variable.

## Configure process alerts using a communication device

### Procedure

Go to **Device Settings** → **Output** → **Process Alert (1 or 2)** → **Alert Settings** → **Configure Process Alert (1 or 2)**.

## 2.6.3

### Re-mapping device variables

Use the **Re-mapping** function to configure the transmitter primary, secondary, tertiary, and quaternary variables (PV, SV, TV, and QV).

#### Note

The variable assigned as the primary variable drives the 4-20 mA output. Possible primary variables include:

- Pressure
- Level
- Volume
- Flow
- Totalizer
- Standard Deviation
- Coefficient of Variation

## Re-map device variables using a communication device

### Procedure

1. Select the primary variable by going to **Device Settings** → **Output** → **Analog Output** → **PV Setup** → **Primary Variable**.
2. Map the secondary variable, tertiary variable, and quaternary variable by going to **Device Settings** → **Communication** → **HART** → **Variable Mapping**.

## 2.7 Configure using Bluetooth® wireless technology

### Procedure

1. Launch AMS Device Configurator.  
See [AMS Device Configurator for Emerson Field Devices](#).
2. Select the device you want to connect to.
3. On first connection, enter the **Unique Identifier (UID)** and **Key** for selected device and select the appropriate role.
4. At the top left, select the menu icon to navigate to the desired device menu.

### 2.7.1 Bluetooth® Unique Identifier (UID) and Key

The **UID** is the identification number unique to the Bluetooth radio on the device.

The **UID** will be advertised when Bluetooth functionality is enabled on the output board. The **Key** is the required passkey to access the device. The information is only available in the tags located as shown in [Figure 2-10](#). Emerson does not retain copies of this information.

You can find the **UID** and **Key** in the following locations:

- Disposable paper tag attached to the device
- Label inside the terminal block cover
- Label on the display unit

**Figure 2-10: Bluetooth Security Information**

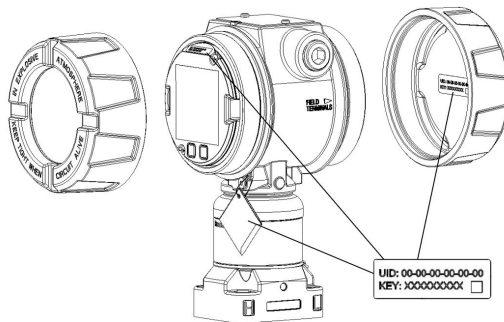

## 2.8 Diagnostics overview

The diagnostics function on the Rosemount 4051S Pressure Transmitter provides operators with a method to proactively identify and alert to common process upsets.

### NOTICE

The diagnostics and service functions in this section are primarily for use after field installation.

Enabling these features reduces the potential of a process shutdown or failure, which could be a safety concern or cause environmental damage. The diagnostic alerts are available from multiple sources, including all asset management systems. These

diagnostics provide insight into the processes supported by operators beyond the basic process variable. This section outlines overviews of each diagnostic as well as the steps for configuration.

## 2.8.1 Overview of **Loop Integrity** diagnostic

You can use the **Loop Integrity** diagnostic to detect issues that may jeopardize the integrity of the electrical loop.

Some examples are:

- Water entering the wiring compartment and making contact with the terminals
- An unstable power supply nearing end of life
- Heavy corrosion on the terminals

The technology is based on the premise that once a transmitter is installed and powered up, the electrical loop has a baseline characteristic that reflects the proper installation. If the transmitter terminal voltage deviates from the baseline and outside the user configured threshold, the transmitter can generate a **HART Status Alert** or **Analog Output Alarm**.

To use the diagnostic, you must first create a baseline characteristic for the electrical loop after installing the transmitter.

The loop is automatically characterized during configuration. The diagnostic creates a linear relationship for expected terminal voltage values along the operating region from 4-20 mA.

See [Figure 2-11](#).

**Figure 2-11: Baseline Operating Region**

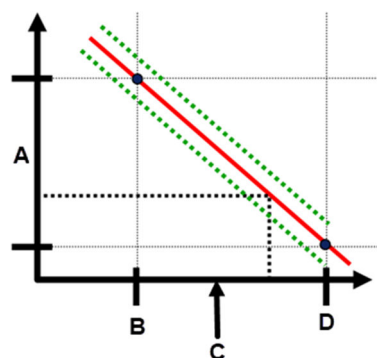

- A. Terminal voltage
- B. 4 mA
- C. Output current
- D. 20 mA

Emerson ships the transmitter with the **Loop Integrity** diagnostic off as a default setting and without any loop characterization performed. Once the transmitter is installed and powered up, you must configure the **Loop Integrity** diagnostic, which performs a loop characterization, for the diagnostic to function.

When you complete the steps for configuring **Loop Integrity**, the transmitter will check to see if the loop has sufficient power for proper operation. The transmitter will then drive the analog output to both 4 and 20 mA to establish a baseline and determine the maximum

allowable voltage deviation. Once this is complete, enter a sensitivity value called **Voltage Deviation Limit**, and a check is in place to ensure the value is valid.

Once you have characterized the loop and set the **Voltage Deviation Limit**, the **Loop Integrity** diagnostic begins to actively monitor the electrical loop for deviations from the baseline. If the voltage has changed relative to the expected baseline value, exceeding the configured **Voltage Deviation Limit**, the transmitter can generate a **HART Status Alert** or **Analog Output Alarm**, depending on what is selected during configuration.

## NOTICE

The **Loop Integrity** diagnostic in the Rosemount 4051S Pressure Transmitter monitors and detects changes in the terminal voltage from expected values to detect common failures. It is not possible to predict and detect all types of electrical failures on the 4-20 mA output. Therefore, Emerson cannot absolutely warrant or guarantee that the **Loop Integrity** diagnostic will accurately detect failures under all circumstances.

## Terminal Voltage

This field shows the current terminal voltage value in volts.

The **Terminal Voltage** is a dynamic value and is directly related to the mA output value.

## Voltage Deviation Limit

Set the **Voltage Deviation Limit** large enough that expected voltage changes do not cause false failures.

Figure 2-12: Voltage Deviation Limit

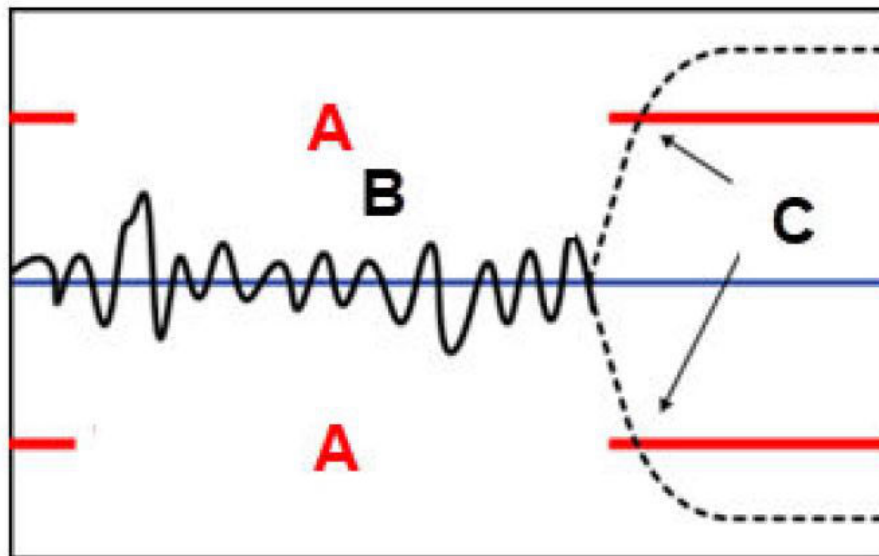

- A. **Voltage Deviation Limit**
- B. *Terminal voltage*
- C. *Alert*

## NOTICE

### Changes in electrical loop

Severe changes in the electrical loop may inhibit HART® communication or the ability to reach alarm values. Therefore, Emerson cannot absolutely warrant or guarantee that the correct **Failure** alarm level (High or Low) can be read by the host system at the time of annunciation.

### Resistance

This value is the calculated resistance of the electrical loop (in ohms) measured during the **Loop Characterization** procedure.

Changes in the resistance may occur due to changes in the physical condition of the loop installation. You can compare baseline and previous baselines to see how much resistance has changed over time.

### Power Supply

This value is the calculated power supply voltage of the electrical loop (in volts) measured during the configuration procedure.

Changes in this value may occur due to degraded performance of the power supply. You can compare baseline and previous baselines to see how much the power supply has changed over time.

### Loop Integrity Notification mode

When you configure **Loop Integrity**, you can select one of three different **Notification** modes.

- Disable Diagnostic
- HART® Status Alert
- Analog Output Alarm

The HART Status Alert setting causes an unlatched alarm, meaning that if the voltage deviation returns to within the set **Voltage Deviation Limit**, the alert will be cleared from the active alerts. However, the event will still be recorded in the **Diagnostic** log.

#### Note

You must configure **Loop Integrity** after installing the transmitter for the first time or after intentionally altering electrical loop characteristics. Emerson does not recommend the **Loop Integrity** diagnostic for transmitters operating in Multi-drop mode.

Examples include:

- Modifying power supply level or loop resistance of the system
- Changing the terminal block on the transmitter
- Adding the Wireless THUM™ Adapter to the transmitter

## Configure Loop Integrity diagnostic using a communication device

### Prerequisites

The transmitter must be installed in an active running process to successfully configure the diagnostic. Ensure that the device is in this state prior to configuring.

### Procedure

1. Go to **Diagnostics** → **Alerts** → **Loop Integrity Diagnostic** → **Configure Loop Integrity**.
2. After the loop characterization has completed, enter the desired **Voltage Deviation Limit**.
3. Select a **Notification Mode**:
  - Disable Diagnostic
  - HART® Status Alert
  - Analog Output Alarm
4. Once the diagnostic is configured, you can adjust the **Notification Mode** and **Voltage Deviation Limit**.

## 2.8.2 Overview of Plugged Impulse Line diagnostic

The **Plugged Impulse Line** diagnostic provides a means to detect plugged impulse lines before impacting operation.

The technology is based on the premise that all dynamic processes have a unique noise or variation signature when operating normally. Changes in these signatures may signal that a significant change will occur or has occurred in the process. The sensing of the unique signature uses software in the electronics to compute statistical parameters that characterize and quantify the noise or variation. These statistical parameters are the standard deviation and coefficient of variation of the input pressure.

The transmitter has a filtering capability to separate slow changes in the process due to set point changes from the process noise or variation of interest.

**Figure 2-13: Changes in Process Noise or Variability and Effect on Statistical Parameters**

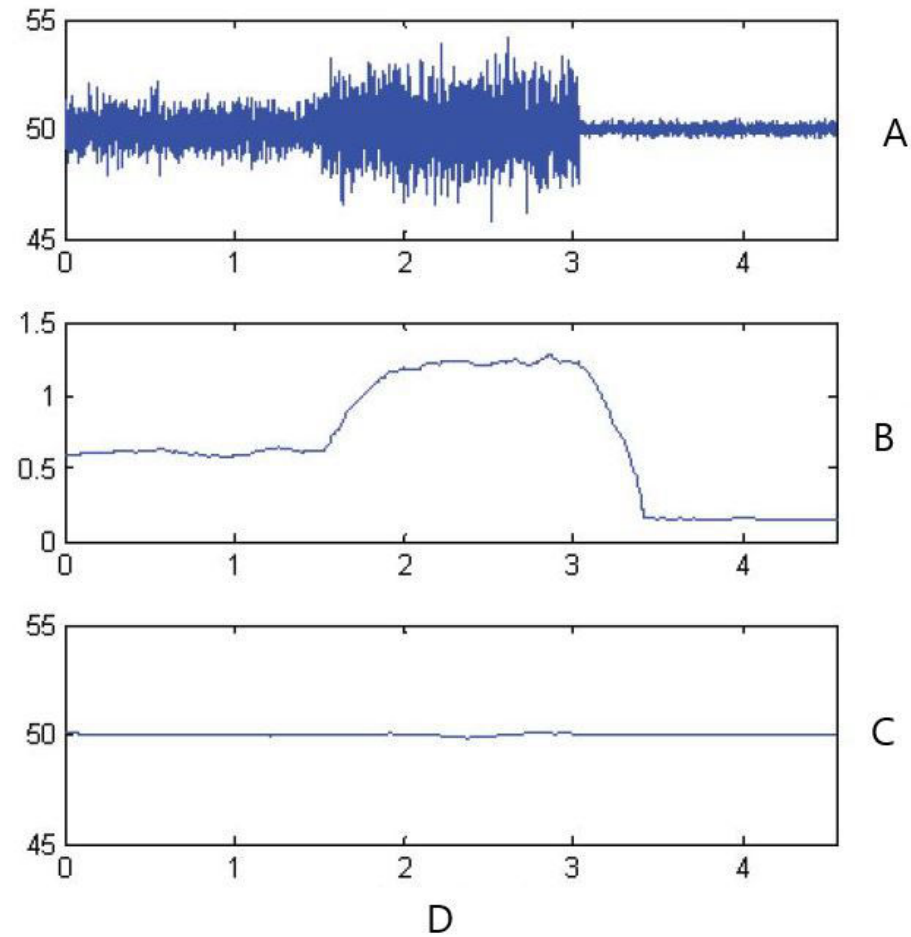

- A. Process noise
- B. Standard deviation
- C. Mean
- D. Time (minutes)

**Note**

Standard deviation increases or decreases with changing noise level.

**Figure 2-14: Coefficient of Variation (CV) is the Ratio of Standard Deviation to Mean**

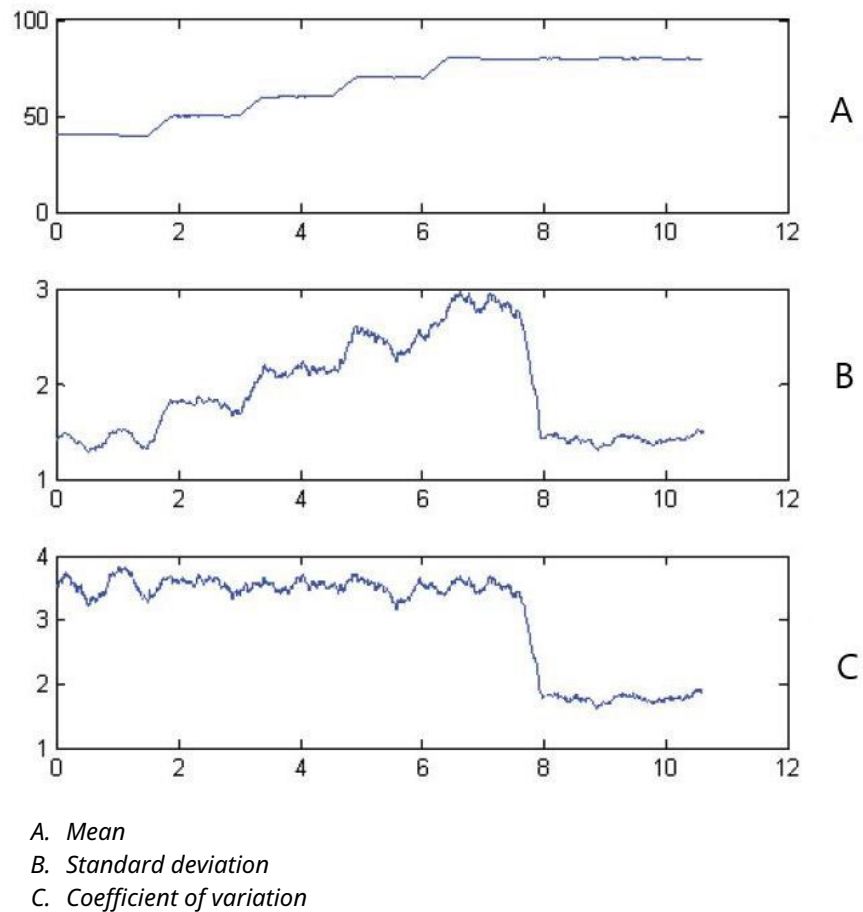

**Note**

CV is stable if mean is proportional to standard deviation.

Typical applications for the **Plugged Impulse Line** diagnostic include detecting abnormal process connection conditions, such as:

- Plugged impulse lines
- Coated or plugged Rosemount Annubar™

**Insufficient Variability check**

The **Plugged Impulse Line** diagnostic uses process noise to baseline the process and detect abnormal situations.

There is an **Insufficient Variability** check to ensure there is sufficient noise for proper operation. In a quiet application with very minimal process noise, the operator will be notified.

## Configure Plugged Impulse Line diagnostic using a communication device

### Prerequisites

The transmitter must be installed in an active running process to successfully configure the diagnostic. Ensure that the device is in this state prior to configuring.

### Procedure

1. Go to **Diagnostics** → **Alerts** → **Plugged Impulse Line Diagnostic** → **Configure Plugged Impulse Line Diagnostic**.
2. Select a notification mode:
  - Disable Diagnostic
  - HART® Status Alert
  - Analog Output Alarm
3. Select whether the transmitter is installed in a flow application or not.
4. Once the diagnostic is configured, you can adjust the level of sensitivity to meet application specific conditions.  
You can set the sensitivity at:
  - Low
  - Medium
  - High

### 2.8.3 Overview of Process Intelligence diagnostic

**Process Intelligence** provides a means for early detection of abnormal situations in the process environment. Typical applications for the **Process Intelligence** diagnostic include detecting abnormal process conditions, such as:

- Furnace flame instability
- Pump cavitation
- Distillation column flooding
- Fluid composition change
- Entrained air
- Agitation loss

Like the **Plugged Impulse Line** diagnostic, this technology is based on the premise that virtually all dynamic processes have a unique noise or variation signature when operating normally. Changes in these signatures may signal that a significant change will occur or has occurred in the process, process equipment, or transmitter installation. For example, the noise source may be equipment in the process such as a pump or agitator, the natural variation in the differential pressure (DP) value caused by turbulent flow, or a combination of both.

The sensing of the unique signature begins with the Rosemount 4051S computing statistical parameters that characterize and quantify the noise or variation. These statistical parameters are the mean, standard deviation, and coefficient of variation (ratio of standard deviation to mean) of the input pressure.

The statistical values of standard deviation and coefficient of variation can be assigned as primary variables, as well as made available to other systems or data historians through

HART® communication. You can also use *WirelessHART*® with the Emerson Wireless 775 THUM™ Adapter to obtain additional variables. Additionally, devices that convert HART variables to analog 4-20 mA outputs, such as the Rosemount 333 Tri-Loop™, can be used. You can assign statistical values to be secondary (SV), tertiary (TV), or quaternary (QV) variables. This is done through **Variable Mapping**.

**Process Intelligence** uses baseline values for the diagnostic to reference. These baseline values are made available to a decision module that compares the baseline values to the most current statistical values. Based on customizable low and high deviation settings, the diagnostic generates alarms or alerts when the deviation thresholds are crossed.

Depending on the configuration, the transmitter continuously calculates the standard deviation or coefficient of variation. The transmitter will monitor for the statistical changes that exceed the user-defined thresholds. This may indicate a change has occurred in the process, equipment, or transmitter installation, and the diagnostic generates a **HART Status Alert** or **Analog Output Alarm**.

---

#### Note

**Process Intelligence** capability in the 4051S Transmitter calculates and detects significant changes in statistical parameters derived from the input pressure signal. These statistical parameters relate to the variability of the noise signals present in the pressure signal. It is difficult to predict specifically which noise sources may be present in a pressure measurement application, the specific influence of those noise sources on the statistical parameters, and the expected changes in the noise sources at any time. Therefore, Emerson absolutely cannot warrant or guarantee that the **Process Intelligence** diagnostic will accurately detect each specific condition under all circumstances.

---

## Process Intelligence variables

These are the statistical variables to be used for **Process Intelligence** diagnostic.

<b>Standard Deviation</b>	Standard Deviation of the process is calculated, and users can set sensitivity thresholds.
<b>Coefficient of Variation (CV)</b>	CV is calculated from the ratio of standard deviation to mean and is better suited for differential pressure (DP) flow applications where the mean pressure is likely to change due to changing process operation. CV puts standard deviation in context of the mean and is represented as a % value. Users can set sensitivity thresholds.

## Insufficient Variability

The **Process Intelligence** diagnostic use process noise to baseline the process and detect abnormal situations.

There is an **Insufficient Variability** check to ensure there is sufficient noise for proper operation. In a quiet application with very minimal process noise, the operator will be notified.

## Setting deviation thresholds

Once you have configured the deviation thresholds, you can adjust them to customize the diagnostic. The deviation thresholds determine the sensitivity level for detecting changes in either the standard deviation or coefficient of variation.

Setting a low deviation threshold percentage would equate to a high sensitivity setting, while a high deviation threshold percentage would equate to a low sensitivity setting.

A high sensitivity setting (low deviation percentage, such as 20 percent) will cause the **Process Intelligence** diagnostic to be more sensitive to changes in the process profile.

A low sensitivity setting (high deviation percentage) will cause the diagnostic to be less sensitive as a much greater change in the process profile is needed to trip the alert.

The deviation threshold can be customized for high and low. This means you can establish a different threshold for the monitored variable, Coefficient of Variation, or Standard Deviation, on the high side and low side.

**Figure 2-15: Deviation Threshold Examples**

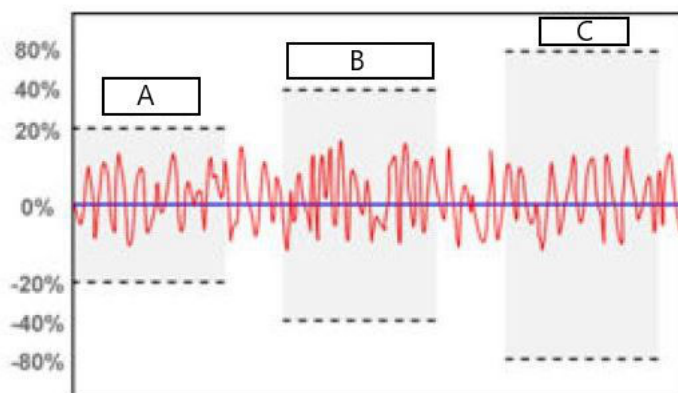

- A. 20 percent
- B. 40 percent
- C. 80 percent

## Damping

This value specifies the amount of delay from when the transmitter detects the deviation threshold being exceeded to generating an alert or alarm.

The valid range is 1 to 3,600 seconds and is user-customizable. Increasing the **Damping** helps to avoid false detections resulting from the Standard Deviation or Coefficient of Variation exceeding the threshold only momentarily.

## Alert Name

The **Alert Name** is a customizable message field related to Standard Deviation/Coefficient of Variation crossing the deviation thresholds.

You can use this message to describe the abnormal process condition or provide additional details for troubleshooting. The message will appear along with the **Process Intelligence** alert. Character limit is 14, including spaces.

## Operational values details

In the transmitter device driver (DD), you can monitor the following details for the monitored statistical variable:

- Current reading
- Baseline value
- Trend graph of the variable over time

You can map the variable to show on the transmitter display or as a HART® variable.

Figure 2-16: Process Intelligence Configuration Screen

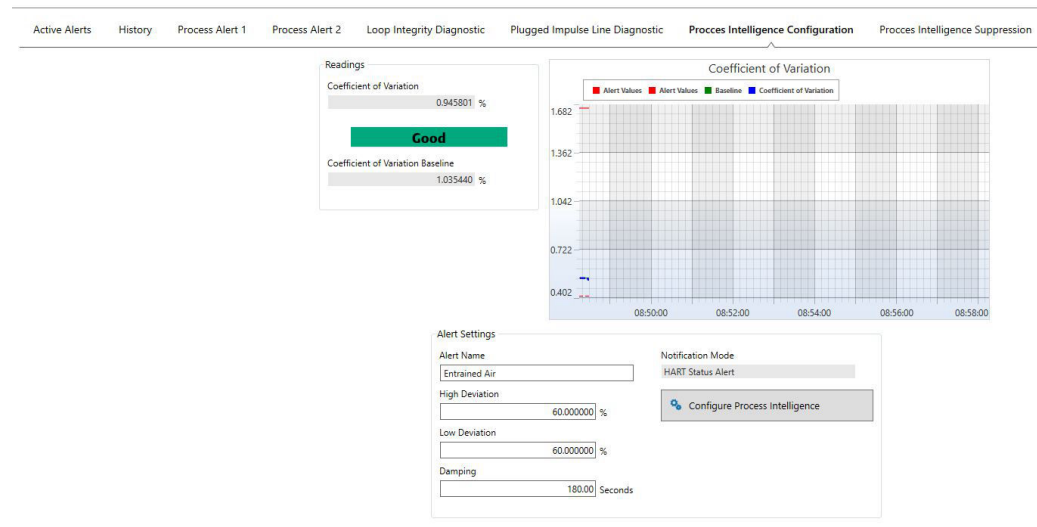

## Alert suppression settings

You can set high and low cut-off settings based on the pressure reading to suppress **Process Intelligence** alerts.

The transmitter will not generate alerts when the pressure is outside of the high and low cut-off range. If necessary, adjust the cut-off values to avoid notifications during process conditions that are not suitable for **Process Intelligence**, such as process shutdown or low flow.

## Configure Process Intelligence diagnostic using a communication device

### Prerequisites

The transmitter must be installed in an active running process to successfully configure the diagnostic. Ensure that the device is in this state prior to configuring.

### Procedure

1. Go to **Diagnostics** → **Alerts** → **Process Intelligence Configuration** → **Configure Process Intelligence**.
2. Select a **Notification Mode**:
  - Disable Diagnostic
  - HART® Status Alert
  - Analog Output Alarm
3. Select the appropriate **Statistical Calculation** for your application. Coefficient of Variation is most appropriate for flow applications, and Standard Deviation is most appropriate for other applications.
4. Set the **Alert Name** that you want to show on the display screen and in the control system when the diagnostic is active. Ensure the device is installed in an actively running process and click **Next**.
5. Once you have configured the diagnostic, you can configure additional parameters to tailor the diagnostic to the specific application.

6. If you need **Alert Suppression**, navigate to the **Process Intelligence Suppression** screen and configure the high and low cut-off values.

## 2.9 Performing transmitter tests

### 2.9.1 Verifying alarm level

If you repair or replace the transmitter electronics board, sensor module, or display, verify the transmitter alarm level before returning the transmitter to service. This is useful in testing the reaction of the control system to a transmitter in an Alarm state, thus ensuring that the control system recognizes the alarm when activated.

To verify the transmitter alarm values, perform a loop test and set the transmitter output to the alarm value.

### 2.9.2 Analog Loop Test

The **Analog Loop Test** command verifies the output of the transmitter, the integrity of the loop, and the operations of any recorders or similar devices installed in the loop.

Emerson recommends testing the 4-20 mA points in addition to alarm levels when installing, repairing, or replacing a transmitter. The host system may provide a current measurement for the 4-20 mA HART® output.

If it does not, connect a reference meter to the transmitter by either connecting the meter to the test terminals on the terminal block or shunting transmitter power through the meter at some point in the loop.

#### Perform Analog Loop Test using a communication device

##### Procedure

Go to **Diagnostics** → **Simulation** → **Loop Test**.

### 2.9.3 Simulate Primary Variable (PV)

You can temporarily set the primary variable to user-defined fixed values for testing purposes. Simulating the primary variable drives the digital reading and the analog output to match the user-defined value.

You can set the primary variable to any of the following output variables:

- Pressure
- Level
- Volume
- Flow Rate
- Totalized Flow
- Standard Deviation
- Coefficient of Variation

## Simulate Primary Variable (PV) using a communication device

### Procedure

Go to **Diagnostics** → **Simulation** → **Simulate PV**.

## 2.10 Configuring Burst mode

Burst mode is compatible with the analog signal. Because the HART® protocol features simultaneous digital and analog data transmission, the analog value can drive other equipment in the loop while the control system is receiving digital information.

Burst mode applies only to the transmission of dynamic data and does not affect the way other transmitter data is accessed. However, when activated, Burst mode can slow down communication of non-dynamic data to the host by 50 percent.

The transmitter accesses information other than dynamic transmitter data through the normal poll/response method of HART communication. A communication device or the control system may request any of the information that is normally available while the transmitter is in Burst mode. Between each message sent by the transmitter, a short pause allows the communication device to initiate a request.

Message content options:

<b>Cmd 1</b>	<b>Read Primary Variable</b>
<b>Cmd 2</b>	<b>Read Percent Range/Current</b>
<b>Cmd 3</b>	<b>Read Dynamic Variables/Current</b>
<b>Cmd 9</b>	<b>Read Device Variables with Status</b>
<b>Cmd 33</b>	<b>Read Device Variables</b>
<b>Cmd 48</b>	<b>Read Additional Device Status</b>

Trigger mode options:

- Continuous
- Rising
- Falling
- Windowed
- On change

---

### Note

You can also opt to use advanced Burst mode capability.

---

## NOTICE

Consult host system manufacturer for Burst mode requirements.

---

### 2.10.1 Configure Burst mode using a communication device

#### Procedure

Go to **Device Settings** → **Output (or Communication)** → **HART** → **Burst Mode Configuration**.

## 2.11 Using High Speed Sensor Response Time (option P6)

The **High Speed Response** option is available with option code P6. This option will change the transmitter response time to 40 ms.

The overall update rate will be dependent on **Damping** settings and if communication is via analog or HART®.



## 3 Hardware installation

### 3.1 Overview

The information provided in this section covers installation considerations for the Rosemount 4051S with HART® protocol.

Emerson ships the [Rosemount 4051S Pressure Transmitters Quick Start Guide](#) with every transmitter to provide basic installation, wiring, and start-up procedures.

Dimensional drawings for each 4051S Pressure Transmitter variation and mounting configuration are included in Type 1 Drawings.

---

#### Note

The following sections contain installation instructions for many optional features. Only follow a section's directions if the transmitter being installed comes with the features described.

---

#### Related information

[Disassembling the transmitter](#)

[Reassembly procedures](#)

### 3.2 Considerations

#### 3.2.1 Installation considerations

Measurement accuracy depends upon proper installation of the transmitter and impulse piping. Mount the transmitter close to the process and use a minimum amount of piping to achieve best accuracy. Keep in mind the need for easy access, personnel safety, practical field calibration, and a suitable transmitter environment. Install the transmitter to minimize vibration, shock, and temperature fluctuation.

#### 3.2.2 Environmental considerations

The best practice is to mount the transmitter in an environment that has minimal ambient temperature change.

The transmitter electronics operating temperature limits are -40 to +185 °F (-40 to +85 °C).

Refer to the *Specifications* section in the [Rosemount 4051S Pressure Transmitter Product Data Sheet](#) to view the sensing element operating limits.

Mount the transmitter so it is not susceptible to vibration and mechanical shock and does not have external contact with corrosive materials.

### 3.2.3 Mechanical considerations

See the [Rosemount 4051S Pressure Transmitter Product Data Sheet](#) for temperature operating limits.

#### NOTICE

Tilting of the transmitter may cause a zero shift in the transmitter output.

Ensure the transmitter is securely mounted.

#### Steam service

For steam service or for applications with process temperatures greater than the limits of the transmitter, take care to avoid allowing the hot process fluid to directly contact the transmitter. Flush impulse lines with the isolation valves to the transmitter closed and refill the lines with liquid before resuming measurement.

#### Side mounted

When the transmitter is mounted on its side, position the Coplanar™ flange to ensure proper venting or draining. Keep drain/vent connections on the bottom for gas service and on the top for liquid service when mounting the flange.

### 3.2.4 Draft range considerations

#### Installation

For the Rosemount 4051SCD0 Draft Range Pressure Transmitter, Emerson recommends mounting the transmitter with the isolators parallel to the ground.

See [Figure 3-1](#) for a draft range installation example on a Rosemount 304 manifold. Installing the transmitter in this way reduces oil head effect.

Tilting of the transmitter may cause a zero shift in the transmitter output, but you can eliminate this by performing a trim procedure.

**Figure 3-1: Draft Range Installation Example**

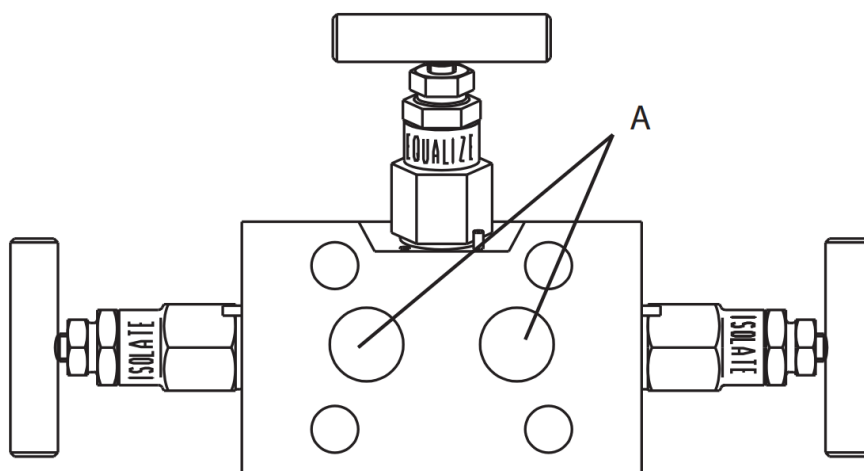

A. Isolators

## Reducing process noise

Rosemount 4051SCD0 Draft Transmitters are sensitive to small pressure changes. Increasing the damping will decrease output noise, but will further reduce response time. In gauge applications, it is important to minimize pressure fluctuations to the low side isolator.

### Output damping

At the factory, Emerson sets the output damping for the 4051SCD0 to 3.2 seconds. If the transmitter output is still noisy, increase the damping time. If you need a faster response, decrease the damping time.

### Reference side filtering

In gauge applications, it is important to minimize fluctuations in atmospheric pressure to which the low side isolator is exposed.

One method of reducing fluctuations in atmospheric pressure is to attach a length of tubing to the reference side of the transmitter to act as a pressure buffer.

## 3.3 Installation procedures

### 3.3.1 Process flange orientation

Mount the process flanges with sufficient clearance for process connections. For safety reasons, place the drain/vent valves so the process fluid is directed away from possible human contact when the vents are used. In addition, consider the need for a testing or calibration input.

### 3.3.2 Mounting the transmitter

For dimensional drawings, refer to the *Documents & Drawings* section on [Rosemount 4051S Pressure Transmitter](#).

#### **⚠ WARNING**

Process connection temperatures above 185 °F (85 °C) require a limited ambient temperature, reduced by a 1:15 ratio. Consider process connection and ambient temperatures when installing the transmitter with hazardous location certifications. See [Table 3-1](#).

**Table 3-1: Intrinsically Safe/Increased Safety**

Process connection temperature	Maximum ambient temperature
-76 to +185 °F (-60 to +85 °C)	158 °F (170 °C)
185 to 250 °F (85 to 121 °C)	158 to 60 °F (70 to 16 °C) <sup>(1)</sup>

<sup>(1)</sup> Maximum ambient temperature is reduced by 1.5 degree for 1 degree temperature rise in the process connection temperature beyond 185 °F (85 °C).

## Rotate housing

You can rotate the electronics housing up to 180 degrees in either direction to improve field access or to better view the optional graphical LCD display.

**Figure 3-2: Transmitter Housing Set Screw**

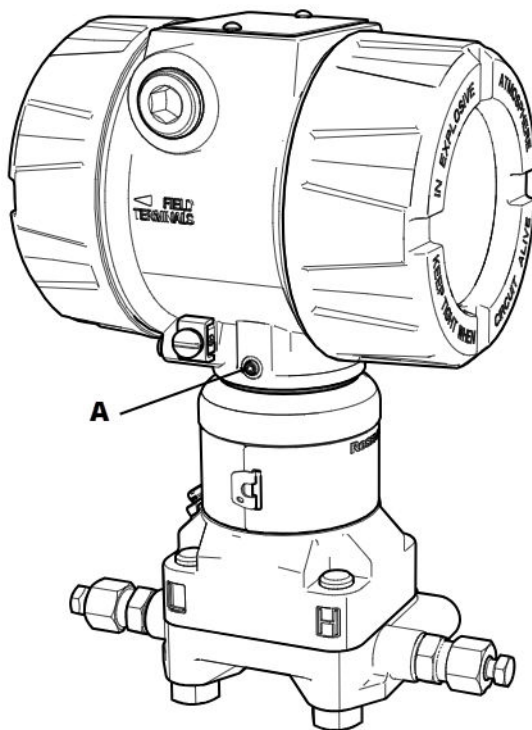

A. Housing rotation set screw ( $\frac{1}{8}$  in.)

### Procedure

1. Loosen the housing rotation set screw using a  $\frac{1}{8}$ -inch hex wrench.

### NOTICE

#### Transmitter damage

Over-rotating can damage the transmitter.

Do not rotate the transmitter more than 180 degrees.

2. Turn the housing left or right up to 180 degrees from its original position.
3. Re-tighten the housing rotation set screw.

## Electronics housing clearance

Mount the transmitter so the terminal side is accessible.

To remove the cover, ensure there is clearance of 0.75 in. (19 mm). Use a conduit plug in the unused conduit opening.

You need 1 in. (26 mm) of clearance to remove the cover if a meter is installed.

## Environmental seal for housing

For ingress protection (for example, Type 4X, IP66, IP68), use an appropriate thread sealing method to provide a water and dust tight seal.

Always ensure a proper seal by installing the electronics housing cover(s) so that metal contacts metal. Use Rosemount O-rings.

## Flange bolts

Emerson can ship the Rosemount 4051S with a Coplanar™ flange or a traditional flange installed with four 1.75-inch flange bolts.

See [Table 3-2](#) for mounting bolts and bolting configurations for the Coplanar and traditional flanges. Emerson supplies stainless steel bolts coated with a lubricant to ease installation. Carbon steel bolts do not require lubrication. Do not apply additional lubrication when installing either type of bolt. Bolts supplied by Emerson are identified by their head markings.

## Install bolts

### **⚠ WARNING**

#### Spare parts

Replacement equipment or spare parts not approved by Emerson for use as spare parts could reduce the pressure retaining capabilities of the transmitter and may render the instrument dangerous.

Use only bolts supplied or sold by Emerson as spare parts.

**Table 3-2: Bolt Installation Torque Values**

Bolt material	Initial torque value	Final torque value
Carbon steel (CS)-(Austemitic [ASTM]-A445) standard	300 in-lb (34 N-m)	650 in-lb (73 N-m)
Austemitic 316 stainless steel (SST)—Option L4	150 in-lb (17 N-m)	300 in-lb (34 N-m)
ASTM A193 Grade B7M—Option L5	300 in-lb (34 N-m)	650 in-lb (73 N-m)

1. Finger-tighten the bolts.
2. Torque the bolts to the initial torque value using a crossing pattern (see [Table 3-2](#) for torque values).
3. Torque the bolts to the final torque value using the same crossing pattern.

Figure 3-3: Traditional Flange Bolt Configurations

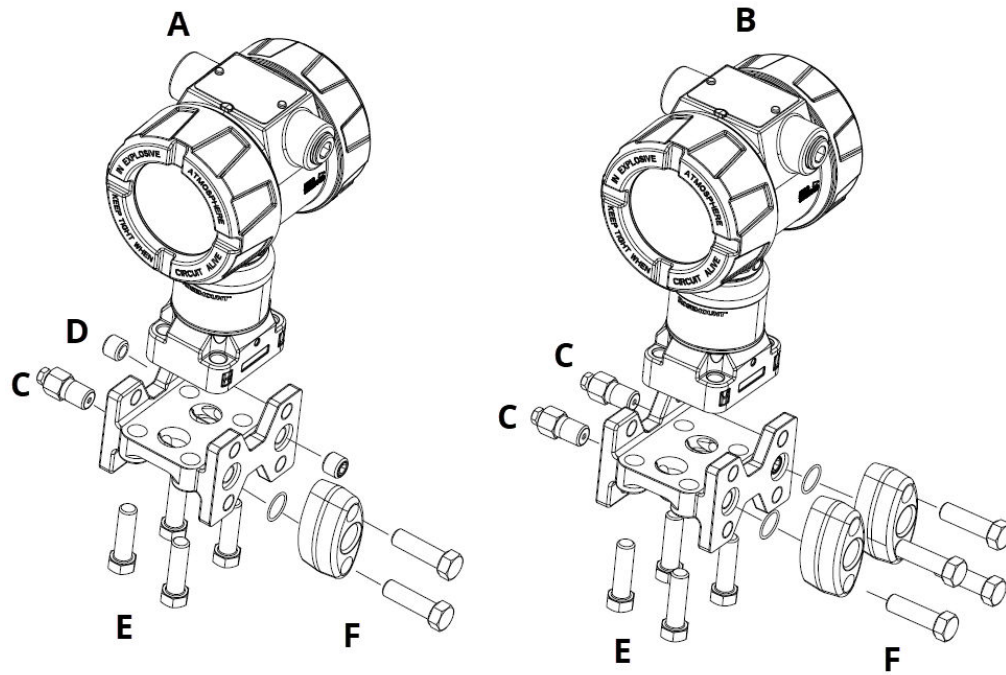

- A. Gauge/absolute transmitter
- B. Differential transmitter
- C. Drain/vent
- D. Vented fitting
- E. 1.75 in. (44 mm) x 4
- F. 1.50 in. (38 mm) x 4<sup>(2)</sup>

You can panel mount or pipe mount the transmitter through an optional mounting bracket.

<sup>(2)</sup> For gauge and absolute transmitters: 150 in. (38 mm) x 2

**Figure 3-4: Flange Bolt Head Markings**

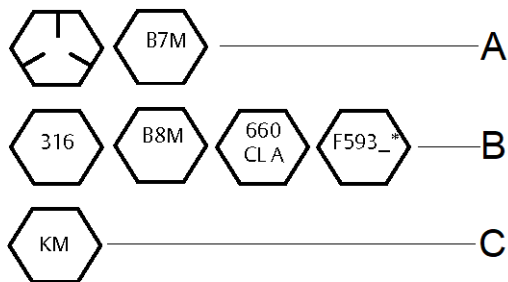

\* The last digit in the F593\_\* heading marking may be any letter between A and M.

- A. CS Head Markings
- B. SST Head Markings
- C. Alloy K-500 Head Markings

**Figure 3-5: Mounting Bolts and Bolt Configurations for Coplanar™ Flange**

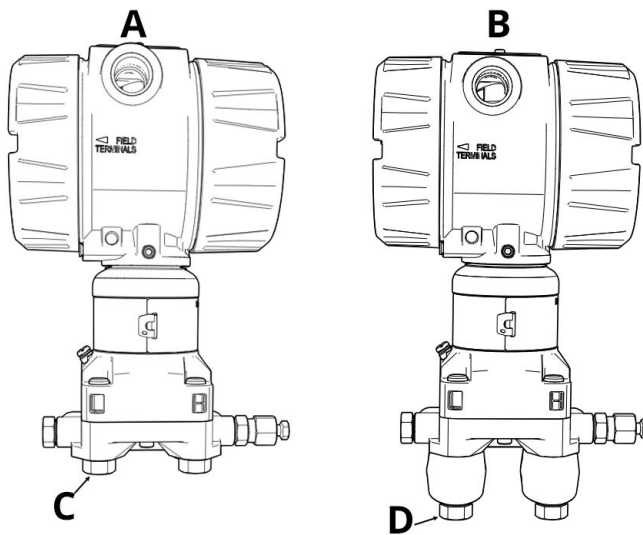

- A. Transmitter with flange bolts
- B. Transmitter with flange adapters and flange/adaptor bolts
- C. 1.75 in. (44 mm) x 4
- D. 2.88 in. (73 mm) x 4

**Note**

Dimensions are in inches (millimeters).

Description	Quantity	Size
<b>Differential pressure</b>		
Flange bolts	4	1.75 in. (44 mm)
Flange/adaptor bolts	4	2.88 in. (73 mm)

Description	Quantity	Size
<b>Gauge/absolute pressure <sup>(1)</sup></b>		
Flange bolts	4	1.75 in. (44 mm)
Flange/adapter bolts	2	2.88 in. (73 mm)

(1) Rosemount 4051ST Transmitters are direct mount and do not require bolts for process connection.

**Figure 3-6: Mounting Bracket Option Code B4**

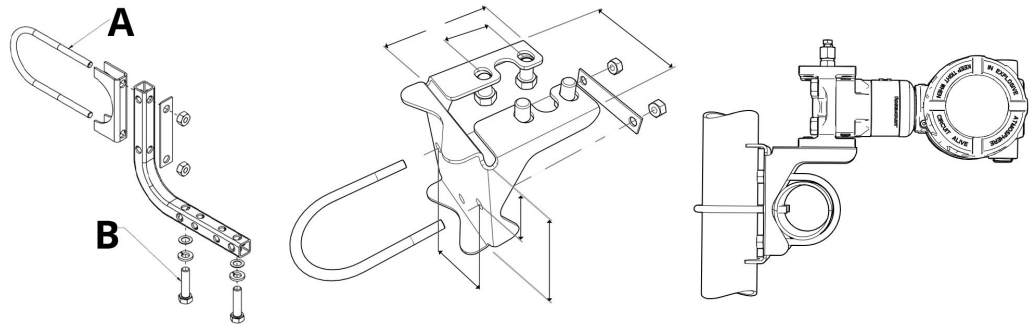

- A. 2-inch U-bolt for pipe mounting
- B.  $\frac{3}{8}$ -16 x 1 $\frac{1}{4}$ -inch bolts for transmitter mounting

**Figure 3-7: Mounting Bracket Option Codes B1, B7, and BA**

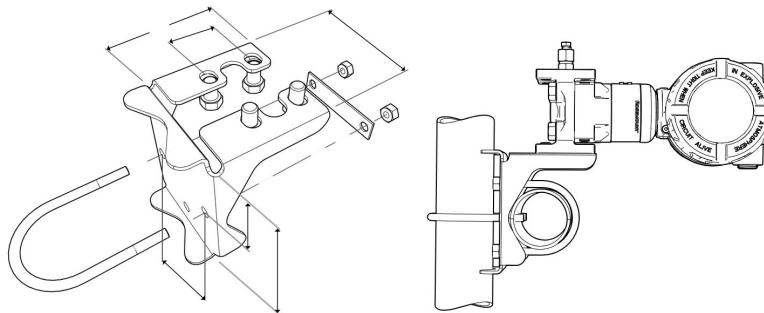

**Note**  
Dimensions are in inches (millimeters).

**Figure 3-8: Panel Mounting Bracket Option Codes B2 and B8**

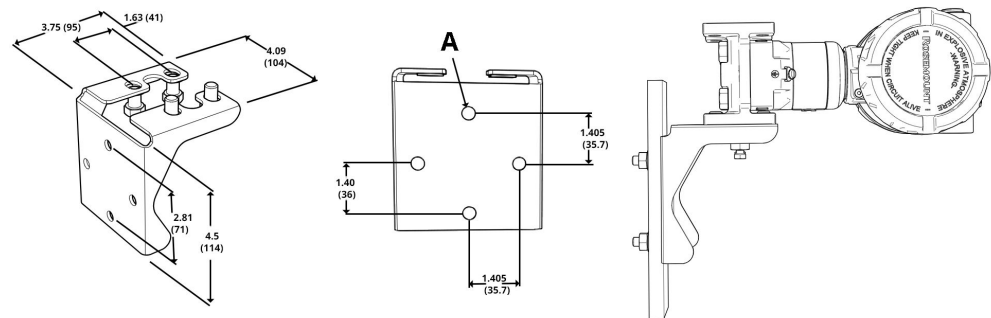

A. Mounting holes  $\frac{3}{8}$ -in. diameter (10)

**Note**

Dimensions are in inches (millimeters).

**Figure 3-9: Flat Mounting Bracket Option Codes B3 and BC**

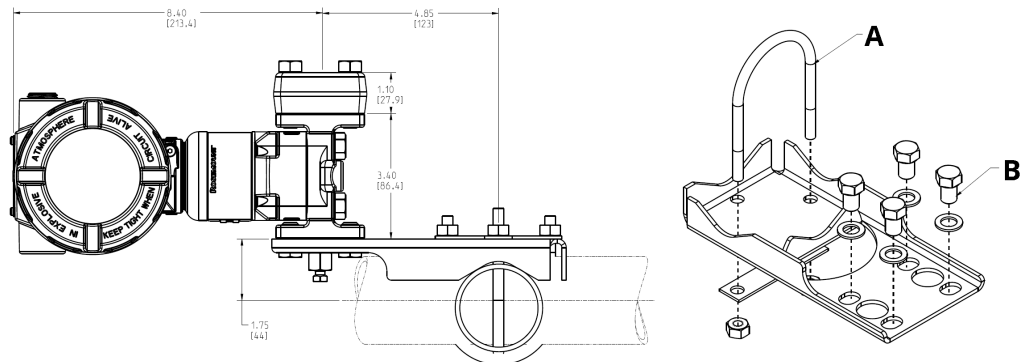

A. 2-inch U-bolt for pipe mounting

B. 7/16-20 x 5/8 bolts for transmitter mounting

**Note**

Dimensions are in inches [millimeters].

### 3.3.3 Impulse piping

#### Mounting requirements

Impulse piping configurations depend on specific measurement conditions. Refer to [Figure 3-10](#) for examples of the following mounting configurations:

##### Liquid measurement

- Place taps to the side of the line to prevent sediment deposits on the transmitter's process isolators.
- Mount the transmitter beside or below the taps so gases can vent into the process line.
- Mount drain/vent valve upward to allow gases to vent.

### Gas measurement

- Place taps in the top or side of the line.
- Mount the transmitter beside or above the taps so liquid will drain into the process line.

### Steam measurement

- Place taps to the side of the line.
- Mount the transmitter below the taps to ensure that the impulse piping will stay filled with condensate.
- In steam service above 250 °F (121 °C), fill impulse lines with water to prevent steam from contacting the transmitter directly and to ensure accurate measurement start-up.

## NOTICE

For steam or other elevated temperature services, it is important that temperatures at the process connection do not exceed the transmitter's process temperature limits.

**Figure 3-10: Installation Examples**

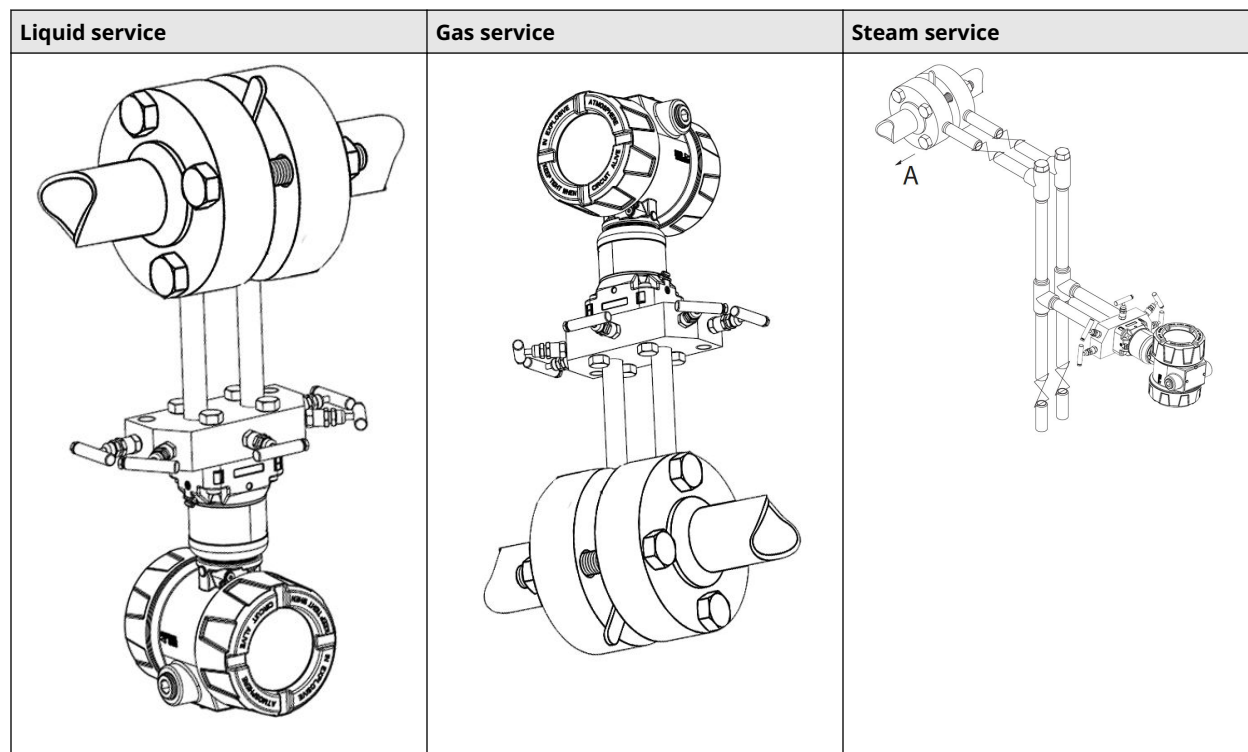

A. Flow

### Best practices

The piping between the process and the transmitter must accurately transfer the pressure to obtain accurate measurements.

There are six possible sources of error:

- Pressure transfer
- Leaks
- Friction loss (particularly if purging is used)
- Trapped gas in a liquid line
- Liquid in a gas line
- Density variations between the legs

The best location for the transmitter in relation to the process pipe is dependent on the process. Use the following guidelines to determine transmitter location and placement of impulse piping:

- Keep impulse piping as short as possible.
- For liquid service, slope the impulse piping at least 1 in/ft (8 cm/m) upward from the transmitter toward the process connection.
- For gas service, slope the piping at least 1 in/ft (8 cm/m) downward from the transmitter toward the process connection.
- Avoid high points in liquid lines and low points in gas lines.
- Ensure impulse legs are the same temperature.
- Use impulse piping large enough to avoid friction effects and blockage.
- Vent all gas from liquid piping legs.
- When using a sealing fluid, fill both piping legs to the same level.
- When purging, make the purge connection close to the process taps and purge through equal lengths of the same size pipe. Avoid purging through the transmitter.
- Keep corrosive or hot (above 250 °F [121 °C]) process material out of direct contact with the sensor modules and flanges.
- Prevent sediment deposits in the impulse piping.
- Maintain equal leg of head pressure on both legs of the impulse piping.
- Avoid conditions that might allow process fluids to freeze within the process flange.

### 3.3.4 Process connections

#### Coplanar™ or traditional process connection

When properly installed, the flange bolts will protrude through the top of the sensor module housing.

#### Install flange adapters

Rosemount 4051S Coplanar™ differential pressure (DP) and gauge pressure (GP) process connections on the transmitter flanges are ¼—18 NPT.

Flange adapters are available with standard ½—14 NPT Class 2 connections. Use the flange adapters to disconnect from the process by removing the flange adapter bolts.

## ⚠ WARNING

### Process leaks

Process leaks could result in death or serious injury.

Install and tighten all four flange bolts before applying pressure.  
Do not attempt to loosen or remove flange bolts while the transmitter is in service.

Use plant-approved lubricant or sealant when making the process connections.

Refer to the *Dimensional drawings* section of the [Rosemount 4051S Pressure Transmitter](#) for the distance between pressure connections.

You can vary the distance by  $\pm\frac{1}{4}$  in. (6.4 mm) by rotating one or both of the flange adapters.

To install adapters to a Coplanar flange:

### Procedure

1. Remove the flange bolts.

Whenever you remove flanges or adapters, visually inspect the PTFE O-rings. If there are any signs of damage, such as nicks or cuts, replace the O-rings with O-rings designed for Rosemount transmitters. You may reuse undamaged O-rings. If you replace the O-rings, retorque the flange bolts after installation to compensate for cold flow.

## NOTICE

If you remove the flange adapter, then replace PTFE O-rings.

2. Leaving the flange in place, move the adapters into position with the O-rings installed.
3. Clamp the adapters and the Coplanar flange to the transmitter sensor module using the larger of the bolts supplied.
4. Tighten the bolts.

## 3.3.5 Inline process connection

### Inline gauge transmitter orientation

## NOTICE

Do not interfere or block the atmospheric reference port, or the transmitter may output erroneous pressure values.

The low side pressure port on the inline gauge transmitter is in the neck of the transmitter, behind the housing. The vent path is 360 degrees around the transmitter between the housing and sensor (see [Figure 3-11](#)).

Keep the vent path free of any obstruction, such as paint, dust, and lubrication, by mounting the transmitter so that the process can drain away.

Figure 3-11: Inline Gauge Low Side Pressure Port

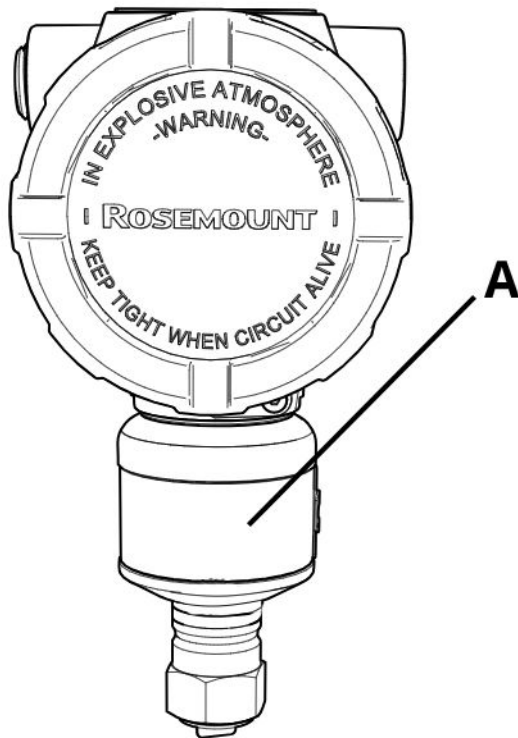

A. Low side pressure port (under neck label)

**NOTICE**

**Electronics damage**

Rotation between the sensor module and the process connection can damage the electronics.

Do not apply torque directly to the sensor module.  
To avoid damage, apply torque only to the hex-shaped process connection. See [Figure 3-12](#).

Figure 3-12: Inline Gauge

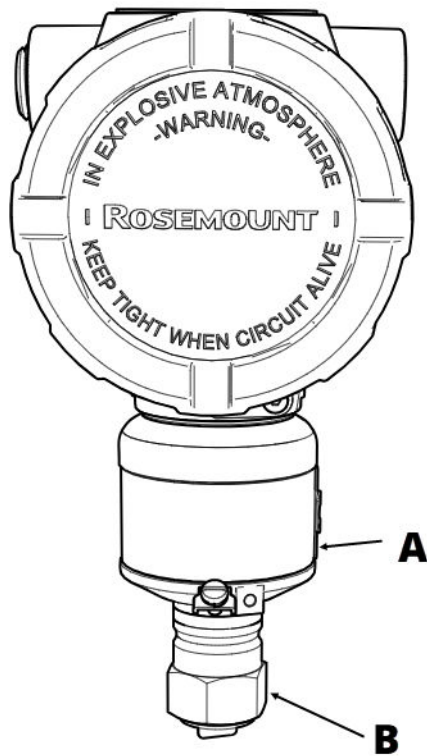

- A. Sensor module
- B. Process connection

### 3.3.6 Rosemount 304, 305, and 306 Manifolds

The 305 Integral Manifold is available in two designs: Traditional and Coplanar™.

You can mount the traditional 305 Integral Manifold to most primary elements with mounting adapters in the market today. The 306 Integral Manifold is used with the Rosemount 4051ST In-Line Transmitters to provide block-and-bleed valve capabilities of up to 10,000 psi (690 bar).

The 304 Conventional Manifold combines a traditional flange and manifold that you can mount to most primary elements.

#### Install Rosemount 304 Conventional Manifold

##### Procedure

1. Align the conventional manifold with the transmitter flange. Use the four manifold bolts for alignment.
2. Finger tighten the bolts; then tighten the bolts incrementally in a cross pattern to the final torque value.  
When fully tightened, the bolts extend through the top of the sensor module housing.
3. Leak-check assembly to maximum pressure range of transmitter.

## Install Rosemount 305 Integral Manifold

### Procedure

1. Inspect the PTFE sensor module O-rings.  
You may reuse undamaged O-rings. If the O-rings are damaged (if they have nicks or cuts, for example), replace with O-rings designed for Rosemount transmitters.

### NOTICE

If replacing the O-rings, take care not to scratch or deface the O-ring grooves or the surface of the isolating diaphragm while you remove the damaged O-rings.

2. Install the integral manifold on the sensor module. Use the four 2¼-inch (57 mm) manifold bolts for alignment. Finger-tighten the bolts; then tighten the bolts incrementally in a cross pattern as seen in [Figure 3-13](#) to final torque value. When fully tightened, the bolts should extend through the top of the sensor module housing.

**Figure 3-13: Bolt Tightening Pattern**

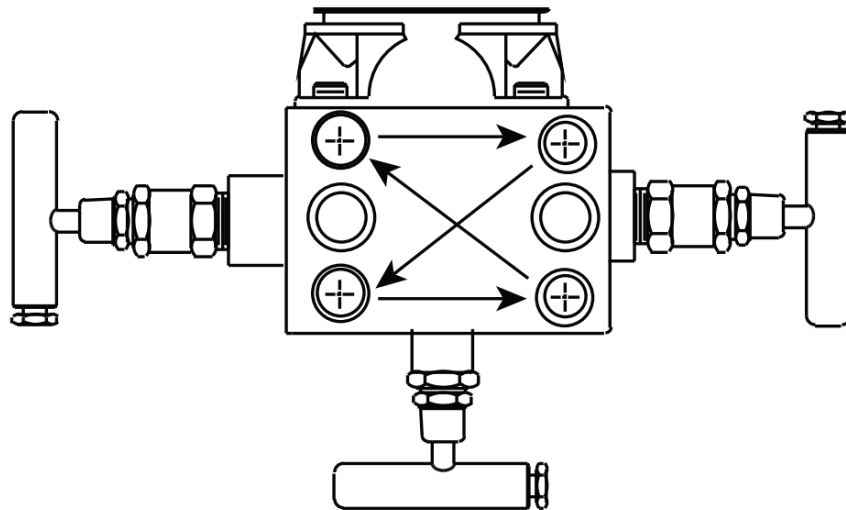

3. If you have replaced the PTFE sensor module O-rings, re-tighten the flange bolts after installation to compensate for cold flow of the O-rings.

## Install Rosemount 306 Integral Manifold

Only use the 306 Manifold with a Rosemount 4051ST In-Line Transmitter.

### **⚠ WARNING**

#### **Process leaks**

Process leaks could result in death or serious injury.

- Install and tighten process connectors before applying pressure.
- Install and tighten all four flange bolts before applying pressure.
- Do not attempt to loosen or remove flange bolts while the transmitter is in service.

---

Assemble the 306 Manifold to the Rosemount 4051ST In-Line Transmitter with a thread sealant.

The proper installation torque value for a 306 Manifold is 425 in-lb.

## Manifold operation

### **⚠ WARNING**

#### **Process leaks**

Process leaks could result in death or serious injury.

Ensure manifolds are installed and operated correctly.

---

Always perform a zero trim on the transmitter/manifold assembly after installation to eliminate any shift due to mounting effects.

#### **Related information**

[Sensor trim overview](#)

## Perform a zero trim on 3 and 5-valve manifolds

Perform zero trim at static line pressure.

In normal operation, the two block valves between the process and instrument ports are open, and the equalizing valve is closed.

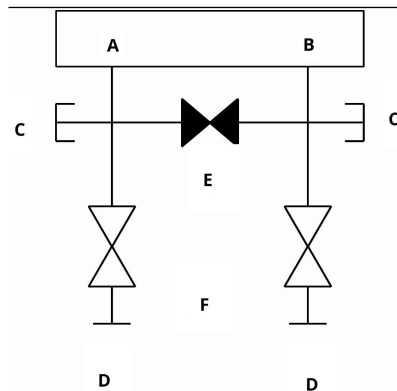

- A. High
- B. Low
- C. Drain/vent valve
- D. Isolate (open)
- E. Equalize (closed)
- F. Process

### Procedure

1. To zero the transmitter, close the block valve to the low pressure (downstream) side first.

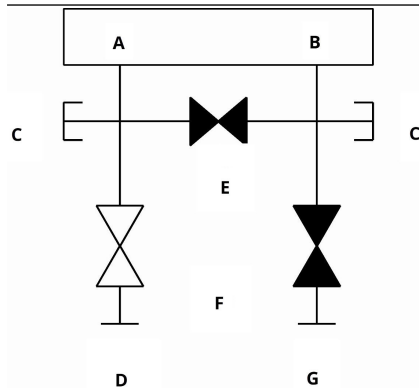

- A. High
- B. Low
- C. Drain/vent valve
- D. Isolate (open)
- E. Equalize (closed)
- F. Process
- G. Isolate (closed)

2. Open the center (equalize) valve to equalize the pressure on both sides of the transmitter.

The manifold valves are now in the proper configuration for zeroing the transmitter.

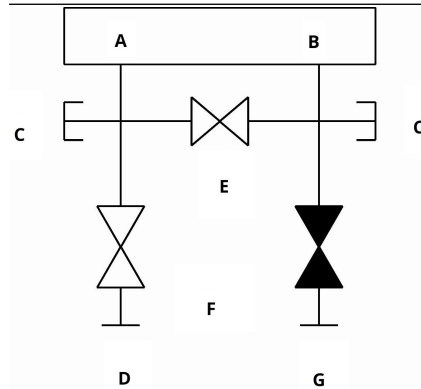

- A. High
- B. Low
- C. Drain/vent valve
- D. Isolate (open)
- E. Equalize (open)
- F. Process
- G. Isolate (closed)

3. After zeroing the transmitter, close the equalize valve.

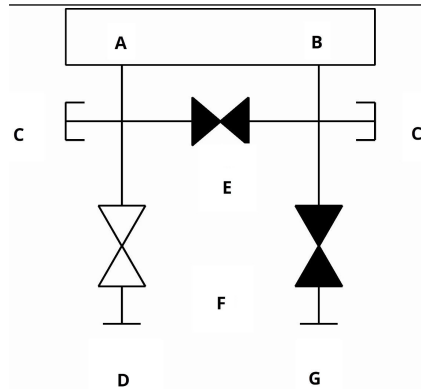

- A. High
- B. Low
- C. Drain/vent valve
- D. Isolate (open)
- E. Equalize (closed)
- F. Process
- G. Isolate (closed)

4. Finally, to return the transmitter to service, open the low side isolate valve. Open the block valve on the low pressure side of the transmitter to return the transmitter to service.

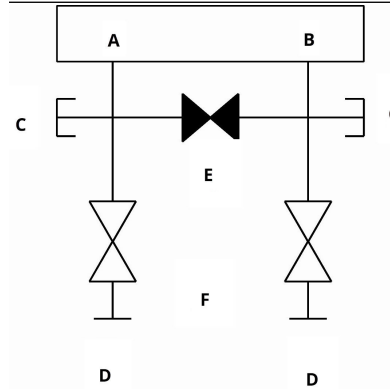

- A. High
- B. Low
- C. Drain/vent valve
- D. Isolate (open)
- E. Equalize (closed)
- F. Process

## Zero a 5-valve natural gas manifold

Perform zero trim at static line pressure.

In normal operation, the two block valves between the process and instrument ports will be open, and the equalizing valves will be closed.

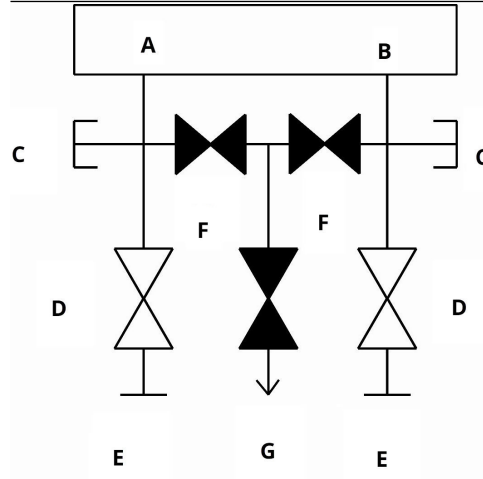

- A. High
- B. Low
- C. Test (plugged)
- D. Isolate (open)
- E. Process
- F. Equalize (closed)
- G. Drain vent (closed)

**Procedure**

1. To zero trim the transmitter, first close the isolate valve on the low pressure (downstream) side of the transmitter and the vent valve. Close the block valve on the low pressure (downstream) side of the transmitter.

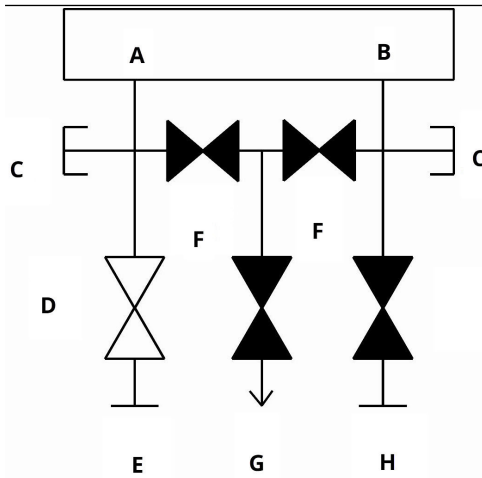

- A. High
- B. Low
- C. Test (plugged)
- D. Isolate (open)
- E. Process
- F. Equalize (closed)
- G. Drain vent (closed)
- H. Isolate (closed)

2. Open the equalize valve on the high pressure (upstream) side of the transmitter.

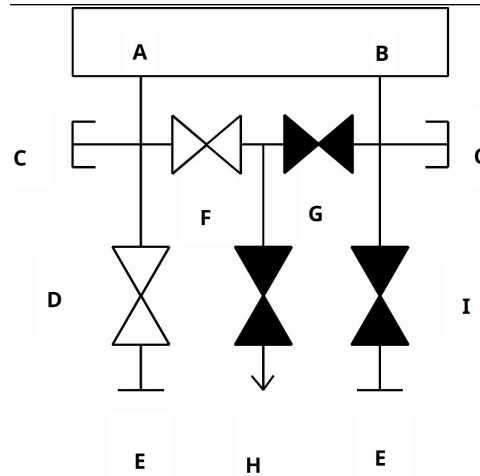

- A. High
- B. Low
- C. Test (plugged)
- D. Isolate (open)
- E. Process
- F. Equalize (open)
- G. Equalize (closed)
- H. Drain vent (closed)
- I. Isolate (closed)

3. Open the equalize valve on the low pressure (downstream) side of the transmitter.  
The manifold is now in the proper configuration for zeroing the transmitter.

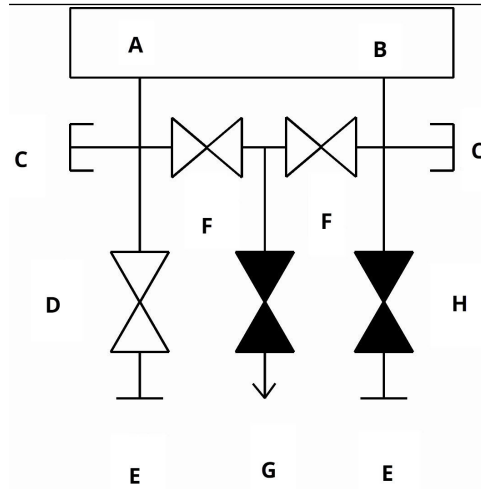

- A. High
- B. Low
- C. Test (plugged)
- D. Isolate (open)
- E. Process
- F. Equalize (open)
- G. Drain vent (closed)
- H. Isolate (closed)

4. After zeroing the transmitter, close the equalize valve on the low pressure (downstream) side of the transmitter.

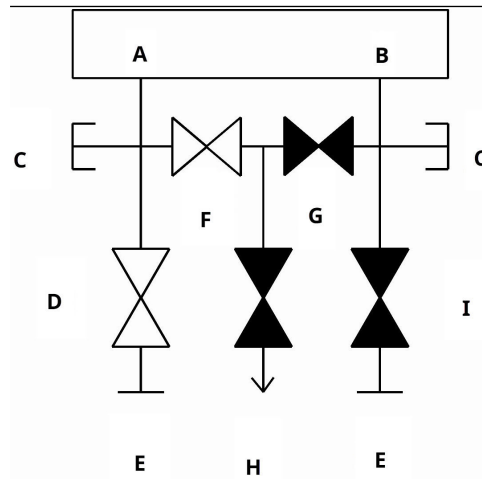

- A. High
- B. Low
- C. Test (plugged)
- D. Isolate (open)
- E. Process
- F. Equalize (open)
- G. Equalize (closed)
- H. Drain vent (closed)
- I. Isolate (closed)

5. Close the equalize valve on the high pressure (upstream) side.

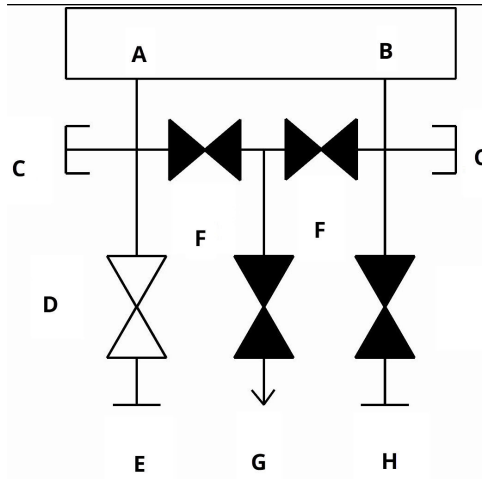

- A. High
- B. Low
- C. Test (plugged)
- D. Isolate (open)
- E. Process
- F. Equalize (closed)
- G. Drain vent (closed)
- H. Isolate (closed)

6. Finally, to return the transmitter to service, open the low side isolate valve and vent valve.

The vent valve can remain open or closed during operation.

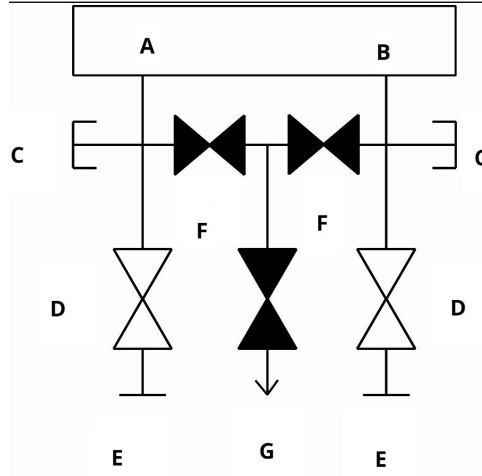

- A. High
- B. Low
- C. Test (plugged)
- D. Isolate (open)
- E. Process
- F. Equalize (closed)
- G. Drain vent (closed)

## 4 Electrical installation

### 4.1 Overview

The information in this section covers installation considerations for the Rosemount 4051S Transmitter.

The *Rosemount 4051S Pressure Transmitters Quick Start Guide* is shipped with every transmitter to describe pipe-fitting, wiring procedures, and basic configuration for initial installation.

### 4.2 Install LCD display

Emerson ships the transmitters ordered with the graphical LCD display option with the display installed.

To install the display on an existing transmitter:

#### **Prerequisites**

Small instrument screwdriver

#### **Procedure**

Carefully align the desired display connectors with the electronics board connector. If the connectors don't align, the display and electronics board are not compatible.

Figure 4-1: LCD Display Assembly

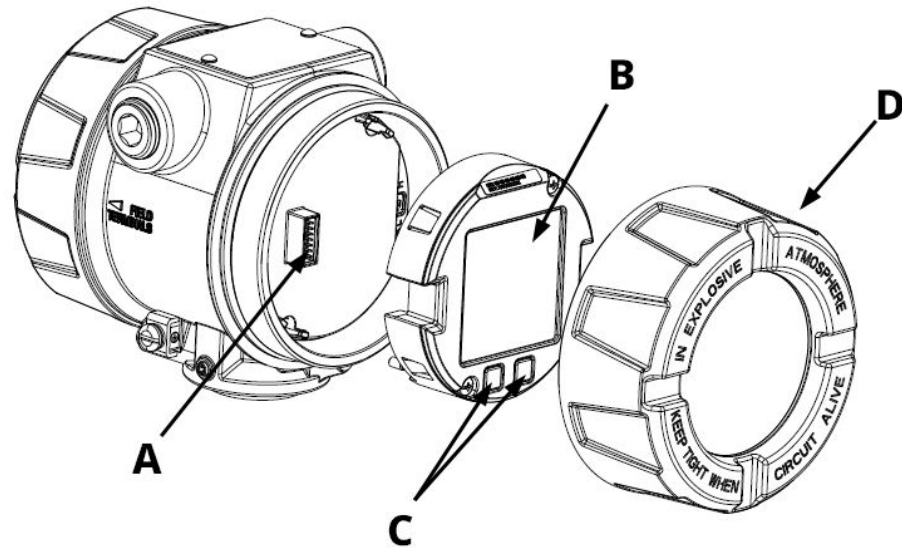

- A. *Interconnecting pins*
- B. *Display*
- C. **Quick Service** buttons
- D. *Cover*

### 4.2.1 Rotate display

If you need to, you can rotate the graphical LCD display in 90-degree increments using software.

You can access this feature with any configuration tool or with the **Quick Service** buttons.

## 4.3 Configuring transmitter security

There are two ways to manage security:

- Hardware security switches
- Software security switches

Figure 4-2: Electronics Board

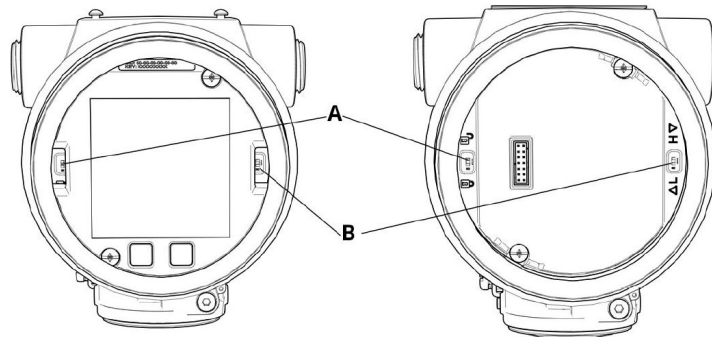

- A. **Security** switch
- B. **Alarm** switch

### 4.3.1 Enable **Security** switch

You can enable the **Security** switch to prevent changes to the transmitter configuration data.

If you set the **Security** switch to Locked, the transmitter will reject any configuration requests sent via HART®, Bluetooth®, or **Quick Service** buttons, and it will not modify configuration data.

See [Figure 4-2](#) for the location of the **Security** switch.

#### Procedure

1. If the transmitter is installed, secure the loop and remove power.

#### **⚠ WARNING**

##### Explosions

Explosions could result in death or serious injury.

In an explosion-proof/flameproof installation, do not remove the transmitter covers when power is applied to the transmitter.

2. Remove the housing cover opposite the field terminal side.

#### **⚠ WARNING**

Do not remove the instrument cover in explosive atmospheres when the circuit is live.

3. Use a small screwdriver to slide the switch to the Lock position.
4. Reattach transmitter housing cover.

Emerson recommends tightening the cover until there is no gap between the cover and housing to comply with explosion-proof requirements.

### 4.3.2 Software Security Lock

The **Software Security Lock** prevents changes to the transmitter configuration from all sources; it rejects all changes requested through HART®, Bluetooth®, and local configuration buttons.

Use a communication device to enable or disable the **Software Security Lock**.

## 4.4 Move Alarm switch

There is an **Alarm** switch on the electronics board to set whether the transmitter will drive to the configured high or low value when in an alarm state.

For switch location, see [Figure 4-2](#).

### Procedure

1. Set loop to Manual and remove power.

#### **⚠ WARNING**

##### **Explosions**

Explosions could result in death or serious injury.

In an explosion-proof/flameproof installation, do not remove the transmitter covers when power is applied to the transmitter.

2. Remove transmitter housing cover.
3. Use a small screwdriver to slide switch to desired position.
4. Replace transmitter cover.

#### **⚠ WARNING**

The cover must be fully engaged to comply with explosion-proof requirements.

### 4.4.1 Install cover jam screw

For transmitter housings shipped with a cover jam screw, install the screw after wiring and powering up the transmitter.

The cover jam screw is intended to prevent removing the transmitter cover in flameproof environments without using tools.

Figure 4-3: Cover Jam Screw

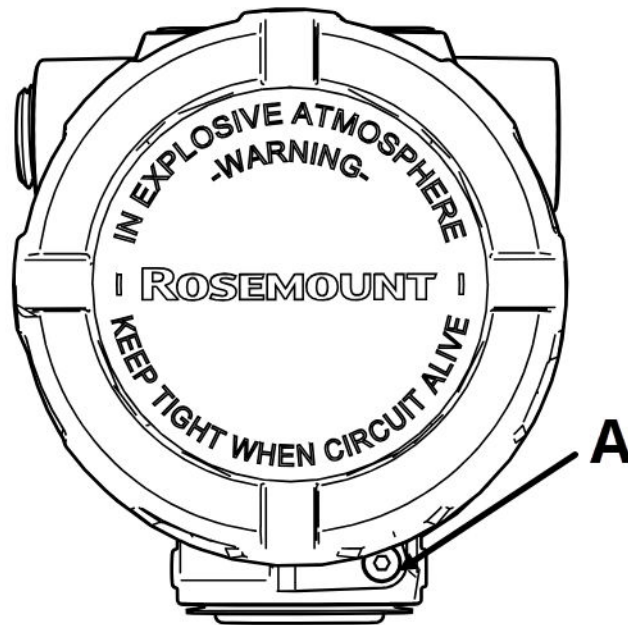

A. Cover jam screw

#### Procedure

1. Verify the cover jam screw is completely threaded into the housing.
2. Install the transmitter housing cover and verify that the cover is tight against the housing.
3. Using an M4 hex wrench, loosen the jam screw until it contacts the transmitter cover.
4. Turn the jam screw an additional  $\frac{1}{2}$  turn counterclockwise to secure the cover.

#### NOTICE

Applying excessive torque may strip the threads.

5. Verify the cover cannot be removed.

## 4.5 Electrical considerations

### ⚠ WARNING

#### Electrical shock

Electrical shock can result in death or serious injury.

Ensure all electrical installation is in accordance with national and local code requirements.

Do not run signal wiring in conduit or open trays with power wiring or near heavy electrical equipment.

### 4.5.1 Conduit installation

#### NOTICE

#### Transmitter damage

If all connections are not sealed, excess moisture accumulation can damage the transmitter.

Mount the transmitter with the electrical housing positioned downward for drainage. To avoid moisture accumulation in the housing, install wiring with a drip loop and ensure the bottom of the drip loop is mounted lower than the conduit connections of the transmitter housing.

Figure 4-4 shows recommended conduit connections.

#### Figure 4-4: Conduit Installation Diagrams

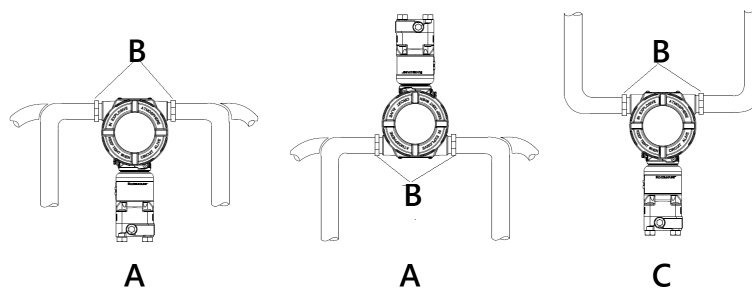

- A. Possible conduit line positions
- B. Sealing compound
- C. Incorrect

### 4.5.2 Power supply for a 4–20 mA HART® communication device

The transmitter operates on 11.5 to 42.4 Vdc at the terminal. The DC power supply must provide power with less than two percent ripple.

Loops with a 250  $\Omega$  resistance require a minimum of 17.4 V.

**Note**

The transmitter must have a minimum of 250 Ω to communicate with a communication device. If you are using a single power supply to power more than one transmitter, ensure the power supply used and the circuitry common to the transmitters do not have more than 20 Ω of impedance at 1,200 Hz.

**Figure 4-5: Load Limitation**

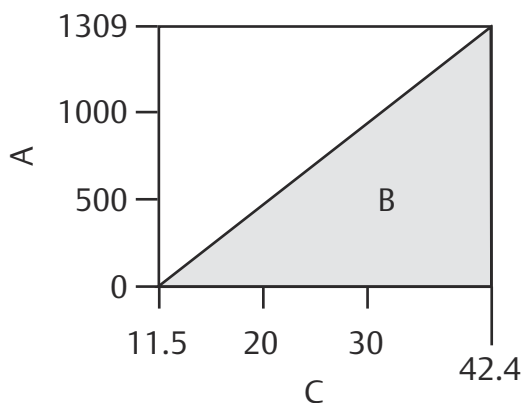

Maximum loop resistance =  $42.37 * (\text{power supply voltage} - 11.5)$

- A. Load (Ω)
- B. Operating region
- C. Voltage (Vdc)

The total resistance load is the sum of the resistance of the signal leads and the load resistance of the controller, indicator, intrinsically safe (IS) barriers, and related pieces. If you use IS barriers, then include the resistance and voltage drop.

### 4.5.3 Wire the transmitter

**⚠ WARNING**

Improper wiring and non-compliance with incorrect procedure risk damage to testing and transmitting equipment, posing potential threats such as explosions

Adherence to proper procedure and usage of specified wiring and correct installation are crucial to ensure safe and effective operation.

**NOTICE**

**Equipment damage**

Incorrect wiring can damage test circuit.

Do not connect the power signal wiring to the test terminals.

**Note**

Use shielded twisted pairs to yield best results. To ensure proper communication, use 24 AWG or larger wire and do not exceed 5,000 ft. (1,500 m).

Figure 4-6: Wiring the transmitter (4-20 mA HART®)

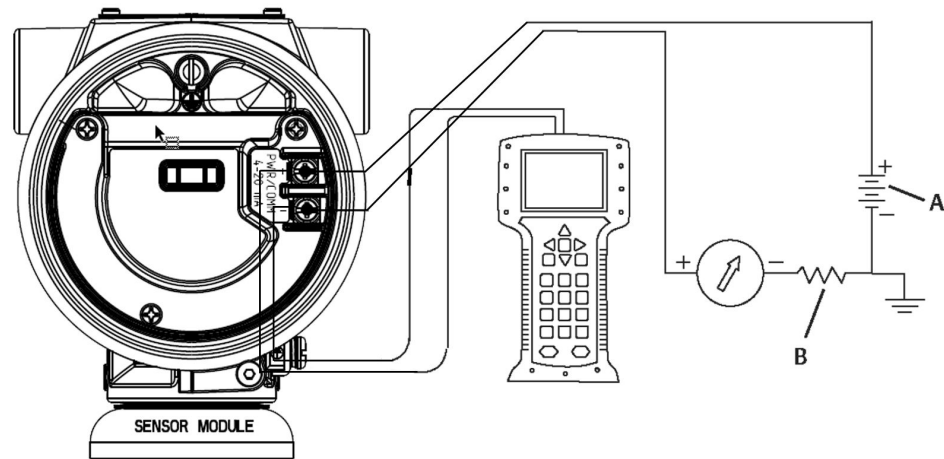

- A. Vdc supply
- B.  $R_L \geq 250$  (necessary for HART communication only)

### Procedure

1. Remove the housing cover on terminal compartment side.

### ⚠ WARNING

#### Explosions

Explosions could result in death or serious injury.

In an explosion-proof/flameproof installation, do not remove the transmitter covers when power is applied to the transmitter.

#### Note

Signal wiring supplies all power to the transmitter.

2. Connect leads.

### NOTICE

#### Equipment damage

Power could damage the test diode.

Do not connect the powered signal wiring to the test terminals.

To connect leads:

- For a 4-20 mA HART output, connect the positive lead to the terminal marked `pwr/comm+` and the negative lead to the terminal marked `pwr/comm-`.
3. Plug and seal unused conduit connections on the transmitter housing to avoid moisture accumulation on the terminal side.

4. Reattach the housing cover and tighten so that metal contacts metal to meet explosion-proof requirements.

## 4.5.4 Ground signal cable shield

Trim and insulate the signal cable shield and unused shield drain wire to ensure that the signal cable shield and drain wire do not contact the transmitter case.

Although [Figure 4-7](#) summarizes signal cable shield grounding, a shielded cable is not required.

**Figure 4-7: Wiring Pair and Ground**

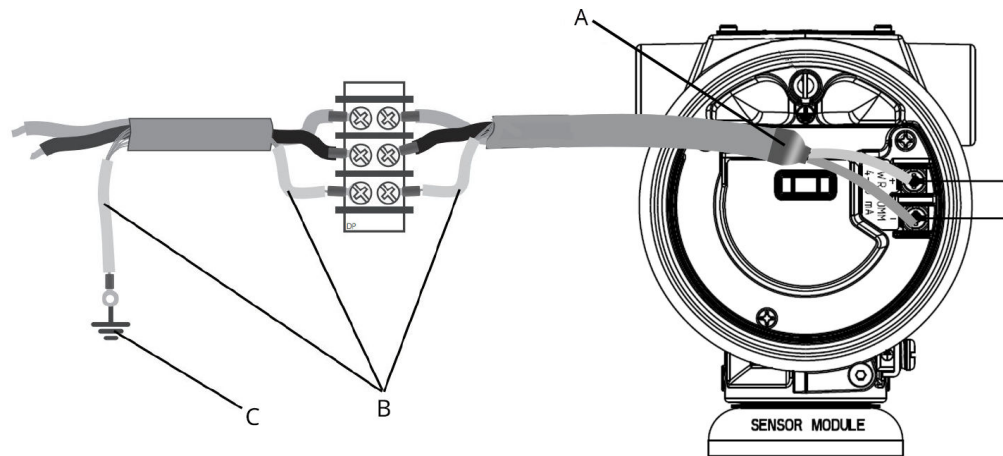

- A. Insulate shield and shield drain wire.*
- B. Insulate exposed shield drain wire.*
- C. Terminate cable shield drain wire to earth ground.*

### Procedure

1. Remove the field terminals housing cover.
2. Connect the signal wire pair at the field terminals as indicated in [Figure 4-7](#).  
Ensure the cable shield is:
  - Trimmed close and insulated from touching the transmitter housing.
  - Continuously connected to the termination point.
  - Connected to a good earth ground at the power supply end.
3. Reattach the field terminals housing cover.  
The cover must be fully engaged to comply with explosion-proof requirements.  
At terminations outside the transmitter housing, verify the cable shield drain wire is continuously connected.  
Prior to the termination point, insulate any exposed shield drain wire as shown in [Figure 4-7](#).
4. Properly terminate the signal cable shield drain wire to an earth ground at or near the power supply.
5. Reattach the housing cover and tighten so that metal contacts metal to meet explosion-proof requirements.

## 4.5.5 Grounding transmitter case

Always ground the transmitter case in accordance with national and local electrical codes. The most effective transmitter case grounding method is a direct connection to earth ground with minimal impedance. Methods for grounding the transmitter case include:

### Internal ground connection

The internal ground connection screw is inside the **FIELD TERMINALS** side of the electronics housing. This screw is identified by a ground symbol (⊕). The ground connection screw is standard on all Rosemount 4051S Transmitters. Refer to [Figure 4-8](#).

**Figure 4-8: Internal Ground Connection**

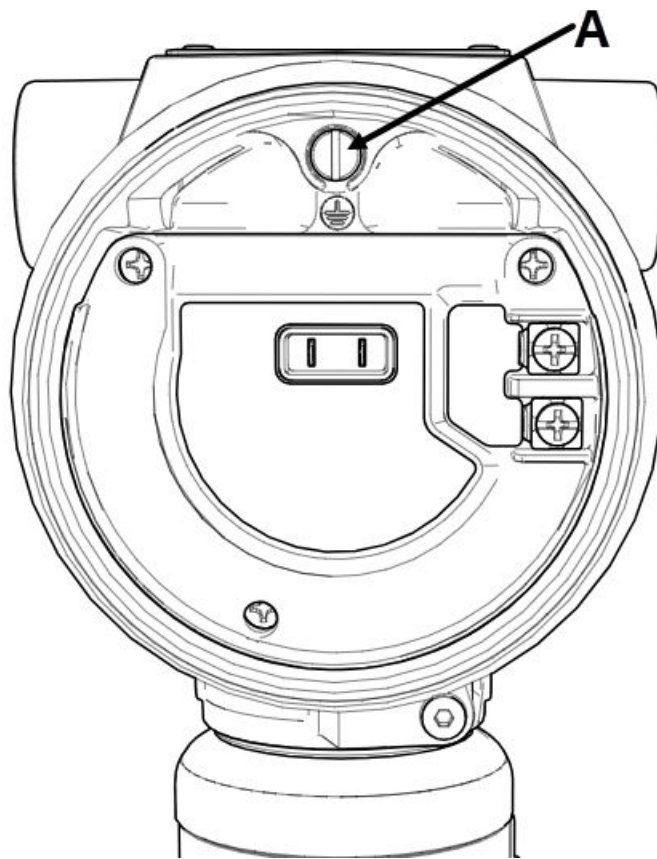

*A. Internal ground location*

### External ground connection

The external ground connection is located on the exterior of the transmitter housing. Refer to [Figure 4-9](#).

This connection is only available with option X1, T1, or applicable product certification codes.

**Figure 4-9: External Ground Connection**

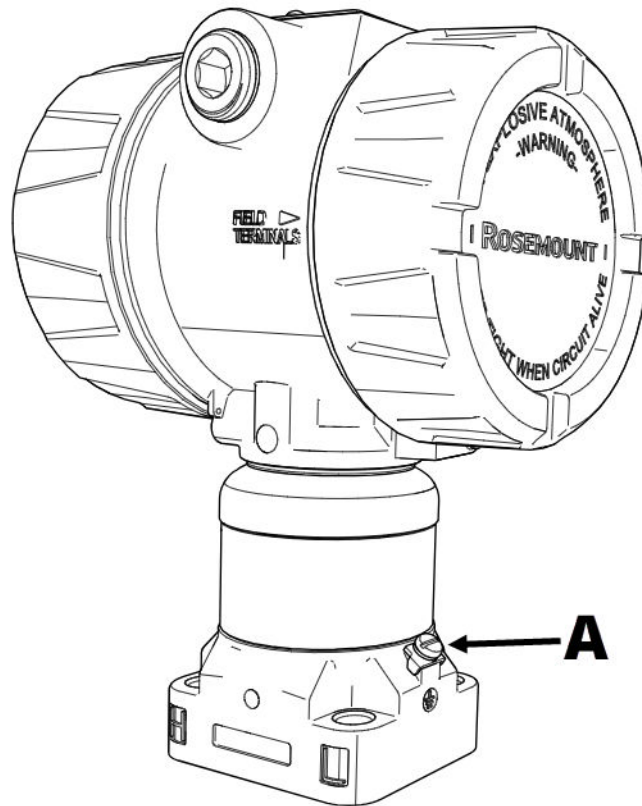

*A. External ground location*

### NOTICE

Grounding the transmitter case via threaded conduit connection may not provide sufficient ground continuity.

## 4.5.6

### Grounding transient protection terminal block

The transmitter can withstand electrical transients of the energy level usually encountered in static discharges or induced switching transients.

### NOTICE

High-energy transients, such as those induced in wiring from nearby lightning strikes, can damage the transmitter.

You can order the transient protection terminal block as an installed option (Option Code T1) or as a spare part to retrofit existing transmitters in the field.

## NOTICE

The transient protection terminal block does not provide transient protection unless the transmitter case is properly grounded. Use the guidelines to ground the transmitter case.

### 4.5.7 Remote display wiring and power up

The remote mount display and interface system consists of a local sensor module and a remote mount LCD display assembly. The local Rosemount 4051S Transmitter assembly includes a housing integrally mounted to a sensor module. The remote mount LCD display assembly consists of a housing with a ten position terminal block.

The following is a list of necessary information specific to the remote mount display system:

- Each terminal block is unique for the remote display system.
- A 316 stainless steel (SST) housing adapter is permanently secured to the remote mount LCD display. The housing providing an external ground and a means for field mounting with the provided mounting bracket.
- A cable is required for wiring between the transmitter and remote mount LCD display. The 04151-9900-XXXX cable length is limited to 500 ft. (152.4 m). Consult Emerson for applications requiring cable length beyond 500 ft. (152.4 m).

#### Remote meter cable specifications

- Maximum cable length: The total length of cable used to connect the remote mounted display assembly and the local sensor module should not exceed maximum lengths below.
- Gray cable up to 500 ft. (152.4 m) for non-intrinsically safe (IS) applications. Consult Emerson for applications requiring beyond 500 ft. (152.4 m).
- Blue cable up to 500 ft. (152.4 m) for non-intrinsically safe (IS) applications. Consult Emerson for applications requiring beyond 500 ft. (152.4 m).
- For Safety Instrumented Systems (SIS), same maximum lengths as listed above.
- Gray and blue cable outside diameter: 0.33 in. (8.38 mm)

## ⚠ WARNING

### Intrinsic safety (IS) consideration

The cable that comes with the transmitter assembly and remote display has been approved (Emerson spare part number 04151-9900-XXXX).

You can use an alternate cable if the transmitter with remote display and cable is configured according to the installation control drawing or certificate. Refer to appropriate approval certificate or control drawing in for remote cable IS requirements.

## NOTICE

Do not apply power to the remote communications terminal. Follow wiring instructions carefully to prevent damage to system components.

## NOTICE

For ambient temperatures above 140 °F (60 °C), cable wiring must be rated at least 9 °F (5 °C) above the maximum ambient temperature.

**Figure 4-10: Remote Mount Display Wiring Diagram**

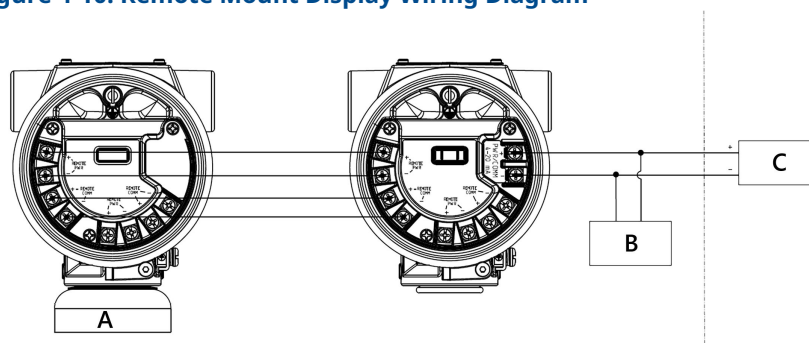

- A. Sensor module
- B. Approved commissioning device
- C. Approved associated apparatus

### Note

Wire color may vary depending on cable selected.

Emerson cable part numbers offered as 04151-9900-XXXX include a ground shield. The shield must be connected to earth ground at the remote display only.

## 4.5.8 eurofast<sup>®</sup>/minifast<sup>®</sup> connection

For transmitters with conduit electrical connectors GE or GM, refer to the cordset manufacturer's installation instructions for wiring details.

For FM flameproof and explosion-proof hazardous locations, install in accordance with requirements to maintain enclosure ratings.

## 4.5.9 Reassemble conduit receptacles

If the conduit receptacle is removed or replaced, see the following instructions to rewire the GE or GM conduit receptacle to the terminal block.

### Procedure

1. Connect the green/yellow lead wire to the internal ground screw.
2. Connect the brown lead wire to the terminal marked *pwr/comm+*
3. Connect the blue lead wire to the terminal marked *pwr/comm-*



## 5 Relay switches (Transmitter output code S)

The Rosemount 4051S Pressure Transmitter supports two integral high voltage, high current single pole double throw (SPDT) switches connected directly to the transmitter. An integral relay switch takes the traditional pressure relay switch and embeds it into the transmitter.

On the 4051S, the relay switches are in the transmitter terminal block. Use the **Process Alert** function to configure the relays, which are controlled by the transmitter measurement.

Depending on how the relay is wired, this will either break or complete the circuit of a connected power load. Each of the two relays has a normally closed (NC) terminal, normally open (NO) terminal, and common (COM) terminal. There is a positive and negative power terminal that powers the switch separately from the positive and negative power terminal that powers the transmitter.

The following sections cover more details on the switch operation, wiring, and configuration.

### Related information

[Relay maintenance and operation \(with output protocol code S\)](#)

### 5.1 Relay terminal block components

If you order the Rosemount 4051S Pressure Transmitter with relay switches, it will come with a different terminal block from the standard transmitter.

The two relay switches are integrated directly into the terminal block as shown in [Figure 5-1](#).

Figure 5-1: Relay Terminal Block

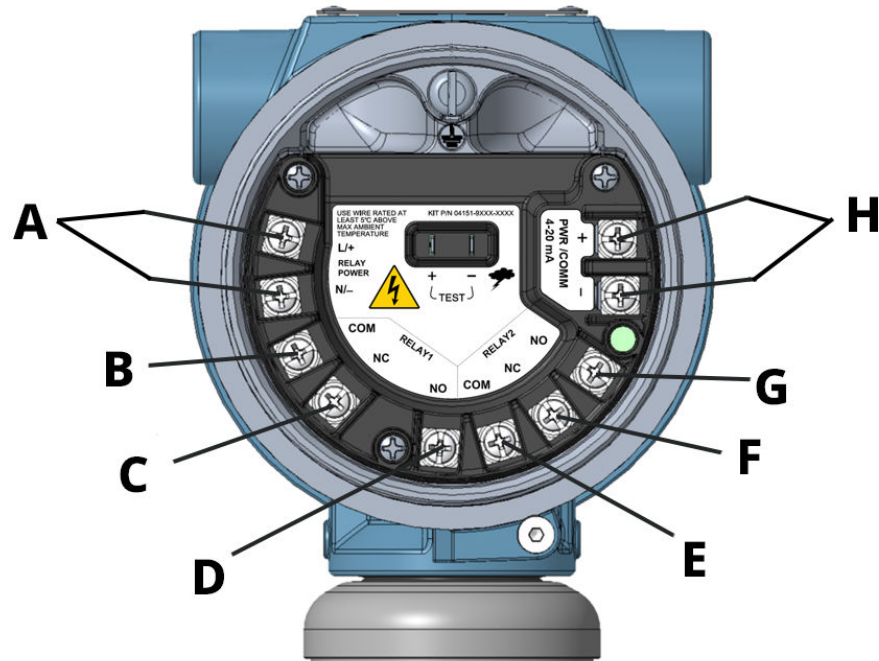

- A. Relay power terminals
- B. Common terminal for Relay switch 1
- C. Normally closed terminal for Relay switch 1
- D. Normally open terminal for Relay switch 1
- E. Common terminal for Relay switch 2
- F. Normally closed terminal for Relay switch 2
- G. Normally open terminal for Relay switch 2
- H. Transmitter power terminals

## 5.2 How relay switches work

This section explains how the relay switches work internally on the Rosemount 4051S Pressure Transmitter.

The switch is an electromechanical relay consisting of three terminals: Common terminal (COM), Normally Closed terminal (NC), and Normally Open terminal (NO). The switch is always connected at COM and either NC or NO.

When the switch has no power or connections, it defaults to its “out of the box” state. This is also the state it will revert to during a power failure. In this state, the physical switch will be positioned between the COM terminal and the NC terminal. Additionally, the switch's configuration during an active alert will determine what the configured position is during an Off state.

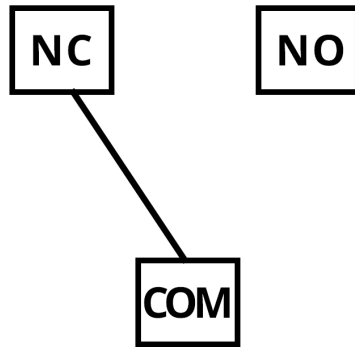

When the switch is Energized, it is positioned between the COM and user-configured terminal, either NO or NC. Based on the configured **Process Alerts**, the transmitter tells the switch when to toggle between Off and Energized.

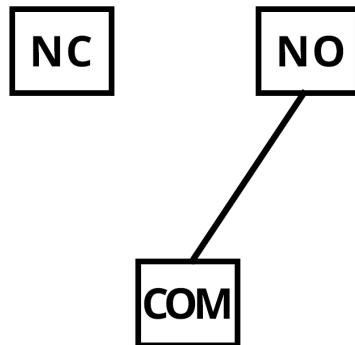

The three states the switch can be in are:

- |                               |   |
|-------------------------------|---|
| <b>Normal Operating state</b> | This refers to the state that the relay is in when the <b>Process Alert</b> is not triggered. This state is user-defined via the <b>Process Alert</b> configuration.  |
| <b>Alert state</b>            | This refers to the state that the relay will go to when the <b>Process Alert</b> is triggered. This state is user-defined via the <b>Process Alert</b> configuration. |
| <b>Fail state</b>             | This refers to the state that the relay will go to when a Failure mode is triggered. This state is always COM to NC.  |

## 5.3 Relay wiring

### NOTICE

Due to the high voltage capabilities of the relay switch, Emerson provides a cover for the terminals.

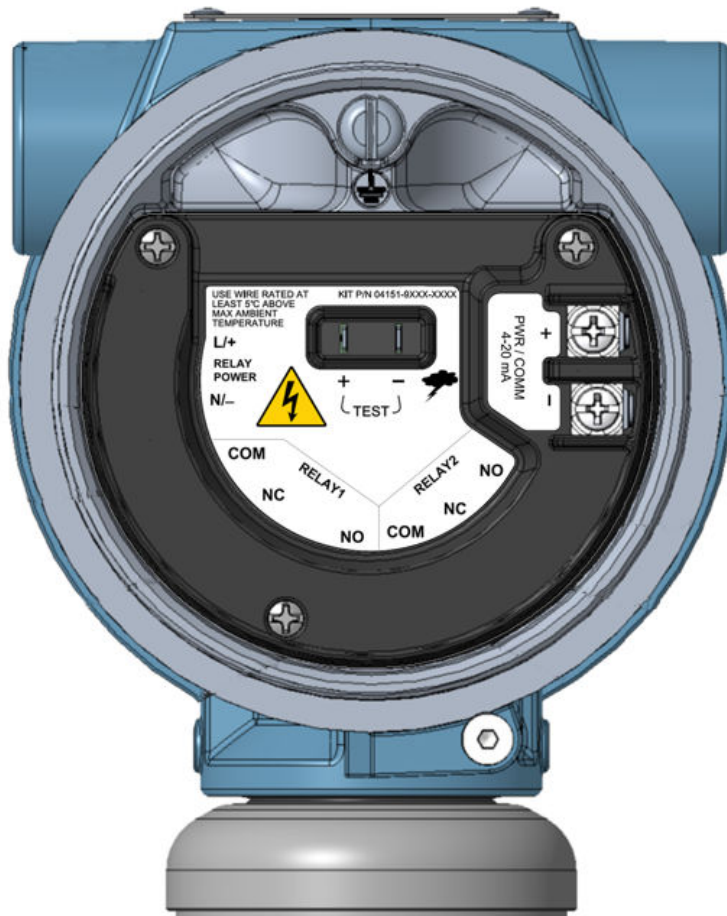

When the switch is in a Fail state, it will always be connected between the Common (COM) and Normally Closed (NC) terminals. The way the relay circuit is wired determines how it will operate when the switch is in a Fail state. If the wires are connected to COM and NC, then the circuit will be closed when in a Fail state. If the wires are connected to COM and NO, then the circuit will be open when in a Fail state. This is where the terms *Normally Closed* and *Normally Open* come from. The terminals that wires are connected to will determine if the circuit is open or closed in a Fail state. The following figures are examples of relay wiring for Normally Open vs. Normally Closed with powered load. The wiring between the transmitter and equipment is green.

Figure 5-2: Normally Open Wiring (left) and Normally Closed Wiring (right)

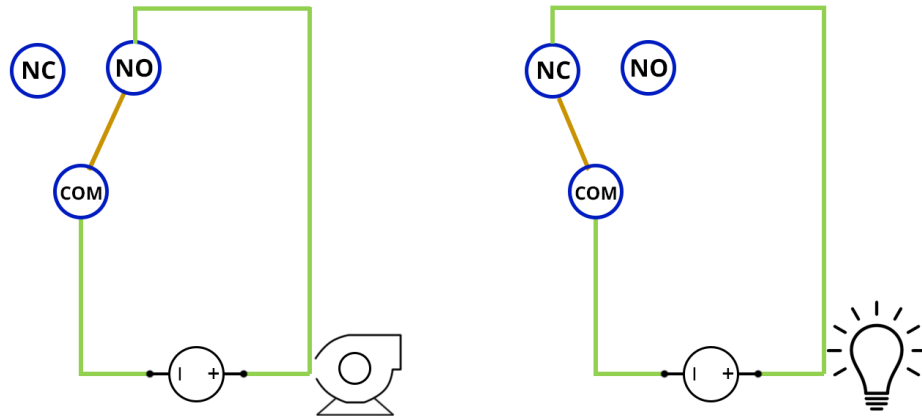

You can see how the loop will be open in a Fail state when wired to COM and NO, and the loop will be closed in a Fail state when wired to COM and NC.

**Important**

Because of this, the COM and NO terminals are used when the relay is being used as a control device if the circuit should be switched Off in the event of a switch failure.

## 5.4 Relay power

The relay switches must be powered by a separate supply from the transmitter power.

As shown in Figure 5-3, there are separate dedicated terminals for the relay power. The power supplied to the relays must be able to sufficiently drive the electromechanical relay coils of both switches to activate them. If using DC power, the terminals are polarity sensitive. If using AC power, there is no polarity sensitivity.

- Transmitter power is 11.5 to 42.4 Vdc.
- Relay power voltage is 21.5 to 60 Vdc or 20 to 264 Vac, 50.60 Hz.
- Relay power current is 5 A maximum resistive load, 3.5 A maximum inductive load.

Table 5-1 shows the Relay 1 and Relay 2 load power requirements.

Table 5-1: Relay Load Power

Parameter		Resistive load	Inductive load
cos $\phi$		1	0.4
L/R		0 ms	7 ms
$I_{MAX}$		5 A	3.5 A
$U_{MAX}$	ac	250 V	250 V
$U_{MAX}$	dc	60 V	60 V
$O_{MAX}$	ac	1,250 VA	875 VA
$O_{MAX}$	dc	240 W	170 W

**⚠ WARNING**

A double pole, single throw (DPST) On/Off switch must be fitted for safe disconnection of the power supply. Fit the DPST switch as near as possible to the pressure relay switch. Keep the DPST switch free of obstructions. Label the DPST switch to indicate it is the supply disconnection device for the power relay switch.

Figure 5-3: Relay Switches

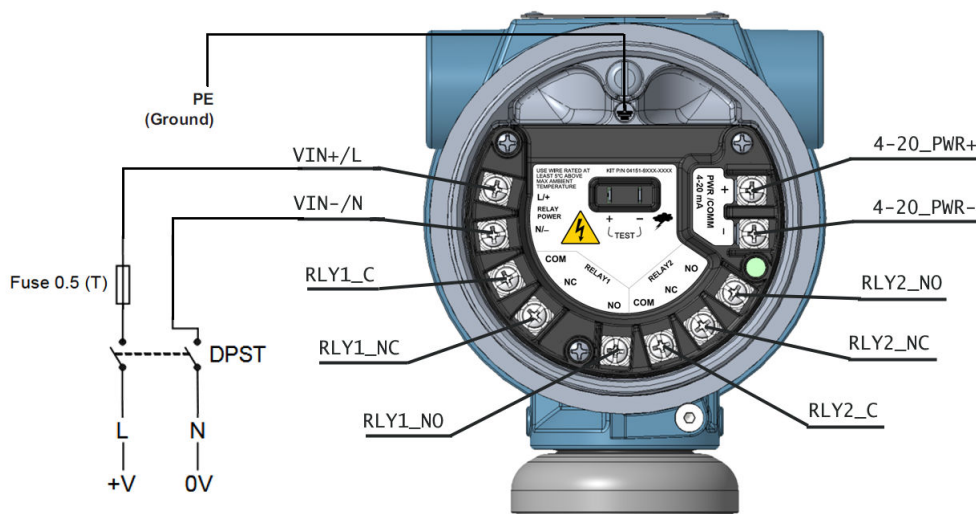

## 5.5 Relay configuration

When wiring AC power to RLYPWR terminals, include a fuse and optional double pole, single throw (DPST) switch.

The external DPST switch shown in [Figure 5-3](#) is an optional local disconnect (customer supplied).

To view relay configuration, go to **Diagnostics** → **Alerts** → **Relay/Process Alert 1 or Relay/Process Alert 2** → **Configure Process Alert**.

### Procedure

1. Select the **Configure Process Alert** method in the transmitter device driver (DD).
2. Select either Relay and HART Status Alert or Relay and Analog Output Alarm for the **Notification Mode** in device setup. The DD will go through the relay setup.
3. Select which variable you want the Process Alert to monitor along with the alert value and whether the status is Above High Side, Inside Window, Outside Window, or Below Low Side. Depending on the selected option, set the high and low alert values. If you select Inside Window or Outside Window, you need to set both high and low alert values.
4. Select **Position During Alert**.

This is the switch's position during an active alert. This tells the software if the switch should be energized (between Common (COM) and Normally Open (NO) or de-energized (between COM and Normally Closed (NC) when in alert. Setting the switch's position will determine if the circuit is open or closed during an alert, but this also depends on how the connection to the relay is wired. For example, if the relay is wired to COM and NO, then when the transmitter switches, the relay will close the loop and power the device you are controlling with the relay.

5. Set up either a **Deadband** or **Time Delay**.
  - The **Deadband** refers to specifying the region from the alert value where no action will occur. For example, if you set the **HART Alert** to 100 inH<sub>2</sub>O and the **Deadband** is 20 inH<sub>2</sub>O, the alert will be triggered at 100 inH<sub>2</sub>O, but the transmitter will not go back to operating conditions until it reaches 80 inH<sub>2</sub>O.
  - The **Time Delay** is the amount of time the alert must be active before the device will report the alert.
6. In addition to configuring **Process Alerts**, you can also set up the relay to show its status on the transmitter display. To configure the transmitter display, go to **Device Settings** → **Display**. Then select which relay you want to show in the secondary area.

---

**Note**

If using two switches at the same time, the physical switching will not be simultaneous in the event that the process alerts signal both switches to activate at the same time.

---

## 5.6 Commissioning a transmitter with relay switches

It is important to consider the sequence of configuring, wiring, and powering both the transmitter and relays when actively using relay switches.

Depending on the relay configuration and wiring, the relay-controlled equipment could receive power, or the transmitter could give early alerts or warnings. To avoid early alerts or warnings, it is important to power the transmitter after powering the relays. In addition, powering both the transmitter and relays prior to configuring the relays will avoid unnecessary trips.

---

**Note**

When performing a bench top configuration with the relay switches, ensure that there is power applied to the relays, power applied to the transmitter, and a load applied to the relay terminals that you are testing. Not applying a load to the relay, will activate the relay diagnostic alert.

---

**Related information**

[Diagnostic messages](#)

## 5.7 Relay switch operation examples

[Table 5-2](#) describes the desired state of the loop between the relay and the device that is being controlled.

For example, if the controlled device should be On in a Fail state, Off in an Operational state, and On in an Alert state, the first row in [Table 5-2](#) would be used.

**Table 5-2: Relay Switch Operation Examples**

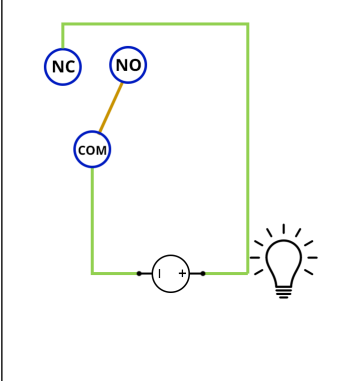
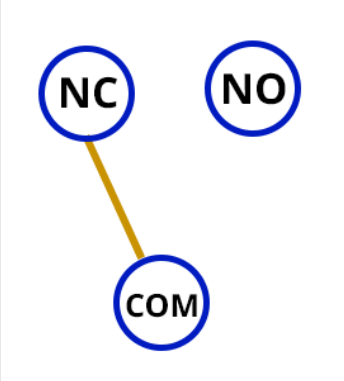
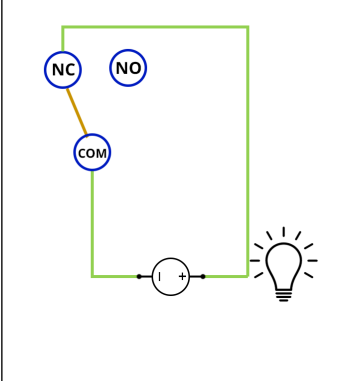
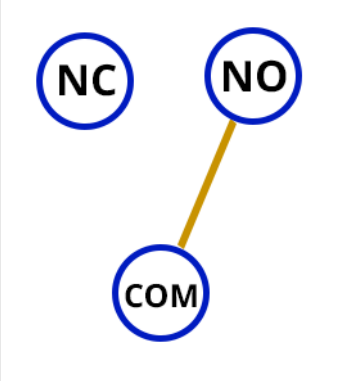
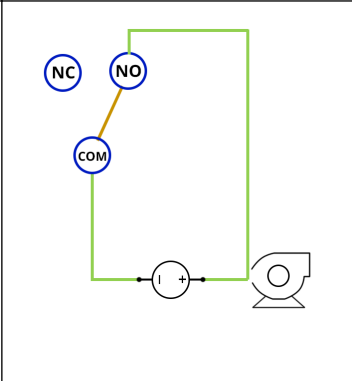
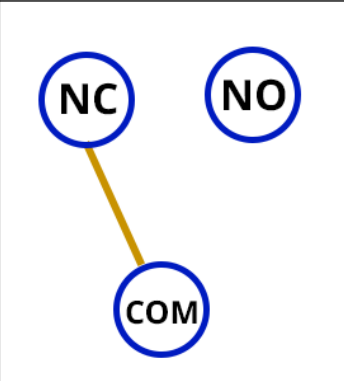
Fail state	Operational state	Alert state	Switch position in Operational state	Switch position in Alert state
Equipment: On	Equipment: Off	Equipment: On		
Equipment: On	Equipment: On	Equipment: Off		
Equipment: Off	Equipment: On	Equipment: Off		

## 5.8 Relay tests

See [Relay maintenance and operation \(with output protocol code S\)](#) to learn more about relay tests and proof tests.

## 5.9 Relay diagnostics

See [Diagnostic messages](#) for more details about relay diagnostic and recommended troubleshooting actions.

# 6 Operation and maintenance

## 6.1 Overview

### NOTICE

#### Calibration

If any trim is done improperly or with inaccurate equipment, it may degrade the transmitter's performance.

Emerson calibrates absolute pressure transmitters at the factory.

Trimming adjusts the position of the factory characterization curve.

---

Emerson provides instructions to perform configuration functions with the following:

- Communication device, such as AMS Trex™ Device Communicator
- AMS Device Manager
- AMS Device Configurator Bluetooth® app
- **Quick Service** buttons

## 6.2 Recommended calibration tasks

### 6.2.1 Calibrate in the field

#### Procedure

1. Perform sensor zero/lower trim to compensate for mounting pressure effects.  
Refer to [Manifold operation](#) for instructions on properly draining and venting valves.
2. Set/check basic configuration parameters:
  - **Damping Value**
  - **Output Type**
  - **Output Units**
  - **Range Points**

### 6.2.2 Calibrate on a bench

#### Procedure

1. Perform optional 4-20 mA output trim.
2. Perform a sensor trim.
  - a) Zero/lower sensor trim for using line pressure effect correction.

Refer to [Manifold operation](#) for instructions on properly draining/venting valves.

- b) Perform the optional full scale trim.  
This sets the span of the device and requires accurate calibration equipment.
- c) Set/check basic configuration parameters.

## NOTICE

To calibrate Rosemount 4051S absolute pressure transmitters range 0 and range 5 devices, you need an accurate absolute pressure source.

## 6.3 Calibration overview

### Note

Emerson fully calibrates the transmitter at the factory. Emerson provides a field calibration option to meet plant requirements or industry standards.

### Note

Sensor calibration allows you to adjust the pressure (digital value) reported by the transmitter to be equal to a pressure standard. The sensor calibration can adjust the pressure offset to correct for mounting conditions or line pressure effects. Emerson recommends this correction.

Also, to calibrate the pressure range (pressure span or gain correction), you need accurate pressure standards (sources) to provide full calibration.

There are two parts to complete calibration of the transmitter: sensor calibration and analog output calibration.

### Calibrating sensor

To perform a sensor trim or digital zero trim, see [Trimming pressure signal](#).

### Calibrating 4-20 mA output

[Perform a 4-20 mA output trim using a communication device](#)

### 6.3.1 Determine necessary sensor trims

With bench calibrations, you can calibrate the device for its desired operation range.

Straightforward connections to pressure source allow for a full calibration at the planned operating points. Exercise the transmitter over the desired pressure range to verify the analog output.

## NOTICE

It is possible to degrade the performance of the transmitter if a trim is done improperly or with inaccurate equipment.

You can set the transmitter back to factory settings using the **Recall Factory Trim** command.

For transmitters that are field installed, manifolds allow the differential transmitter to be zeroed using the zero trim function. This field calibration will eliminate any pressure offsets caused by mounting effects (head effect of the oil fill) and static pressure effects of the process.

To determine the necessary trims:

#### Procedure

1. Apply pressure.
2. Check digital pressure; if the digital pressure does not match the applied pressure, perform a digital trim.
3. Check reported analog output against the live analog output. If they do not match, perform an analog output trim.

## 6.3.2 Determine calibration frequency

Calibration frequency can vary greatly depending on the application, performance requirements, and process conditions. See [How to Calculate Pressure Transmitter Calibration Intervals Technical Note](#).

To determine the calibration frequency that meets the needs of your application:

#### Procedure

1. Determine the performance required for your application.
2. Determine the operating conditions.
3. Calculate the total probable error (TPE).
4. Calculate the stability per month.
5. Calculate the calibration frequency.

### Sample calibration frequency calculation

0.025% span accuracy and 20-year stability

#### Procedure

1. Determine the performance required for your application.

**Required performance** 0.20% of span

2. Determine the operating conditions.

**Transmitter** Rosemount 4051S\_CD, Range 2 (upper range value [URL] = 250 inH<sub>2</sub>O [622.1 mbar])

**Calibrated span** 150 inH<sub>2</sub>O (373.3 mbar)

**Line pressure** 500 psig (34.5 barg)

3. Calculate total probable error (TPE).

$$\text{TPE of span} = \sqrt{(\text{ReferenceAccuracy})^2 + (\text{TemperatureEffect})^2 + (\text{StaticPressureEffect})^2} = 0.0687\% \text{ of span}$$

Where:

**Reference accuracy** 0.025%

**Ambient temperature effect**  $\left[ \frac{(0.009 \times URL)}{Span} + 0.025 \right]$  % of span per 50°F =  
 $\pm 0.04\%$  of span

**Span static pressure effect** <sup>(3)</sup> 0.1% reading per 1000 psi (69 bar) =  $\pm 0.05\%$  of span

4. Calculate the stability per month.

$$\text{Stability} = \pm \left[ \frac{0.1 \times URL}{Span} \right] \% \text{ of span for 20 years} = \pm 0.000694\% \text{ of span for 1 month}$$

5. Calculate calibration frequency.

$$\text{Calibration frequency} = \left[ \frac{(\text{Req. Performance} - TPE)}{\text{Stability per month}} \right] = \frac{0.2\% - 0.0687\%}{0.000694\%} = 189 \text{ months}$$

### 6.3.3 Compensating for span line pressure effects (Range 4 and 5)

Rosemount 4051S Range 4 and 5 Pressure Transmitters require a special calibration procedure when used in differential pressure applications. The purpose of this procedure is to optimize transmitter performance by reducing the effect of static line pressure in these applications.

The 4051S Differential Pressure Transmitters (ranges 0 through 3) do not require this procedure, because optimization occurs at the sensor.

The systematic span shift caused by the application of static line pressure is -1 percent of reading per 1,000 psi (69 bar) for Range 4 transmitters and -1.25 percent of reading per 1,000 psi (69 bar) for Range 5 transmitters.

#### Compensate for span line pressure effect (example)

A Range 4 differential pressure transmitter is used in an application with a static line pressure of 1200 psi (83 bar). The differential pressure (DP) measurement span is from 500 inH<sub>2</sub>O (1.2 bar) to 1,500 inH<sub>2</sub>O (3.7 bar). A Range 4 differential pressure HART<sup>®</sup> transmitter is used in an application with a static line pressure of 1,200 psi (83 bar). The transmitter output is ranged with 4 mA at 500 inH<sub>2</sub>O (1.2 bar) and 20 mA at 1,500 inH<sub>2</sub>O (3.7 bar). To correct for systematic error caused by high static line pressure, first use the following formulas to determine the corrected values for the high trim value.

#### High trim value

$$HT = (URV - [S/100 \times P/1000 \times LRV])$$

Where:

- HT** Corrected high trim value
- URV** Upper range value
- S** Span shift per specification (as percent of reading)
- P** Static line pressure in psi

In this example:

**URV** 1,500 inH<sub>2</sub>O (3.7 bar)

<sup>(3)</sup> Zero static pressure effect removed by zero trimming at line pressure.

S	-1.00%
P	1,200 psi
HT	$1,500 \text{ inH}_2\text{O} + (1.00\%/100 \times 1,200 \text{ psi}/1,000 \text{ psi} \times 1,500 \text{ inH}_2\text{O})$
HT	1,518 inH <sub>2</sub> O

Complete the upper sensor trim procedure as described in [Trimming pressure signal](#). In the preceding example, when calculating the stability per month, apply the nominal pressure value of 1,500 inH<sub>2</sub>O Lo. However, enter the calculated correct upper sensor trim value of 1,518 inH<sub>2</sub>O with a communication device.

## 6.4 Trimming pressure signal

### 6.4.1 Sensor trim overview

A sensor trim corrects the pressure offset and pressure range to match a pressure standard.

The upper sensor trim corrects the pressure range, and the lower sensor trim (zero trim) corrects the pressure offset. An accurate pressure standard is required for full calibration. You can perform a zero trim if the process is vented or the high and low side pressure are equal (for differential pressure transmitters).

Zero trim is a single-point offset adjustment. It is useful for compensating for mounting position effects and is most effective when performed with the transmitter installed in its final mounting position. As this correction maintains the slope of the characterization curve, do not use it in place of a sensor trim over the full sensor range.

When performing a zero trim, ensure that the equalizing valve is open and all wet legs are filled to the correct levels. Apply line pressure to the transmitter during a zero trim to eliminate line pressure errors.

---

#### Note

Do not perform a zero trim on an absolute pressure transmitter. Zero trim is zero based, and absolute pressure transmitters reference absolute zero. To correct mounting position effects on an absolute pressure transmitter, perform a lower sensor trim within the sensor trim function. The lower sensor trim function provides an offset correction similar to the zero trim function, but it does not require zero-based input.

---

Upper and lower sensor trim is a two-point sensor calibration where two end-point pressures are applied and all output is linearized between them; this calibration also requires an accurate pressure source. Always adjust the low trim value first to establish the correct offset. Adjustment of the high trim value provides a slope correction to the characterization curve based on the low trim value. The trim values help optimize performance over a specific measurement range.

Figure 6-1: Sensor Trim Example

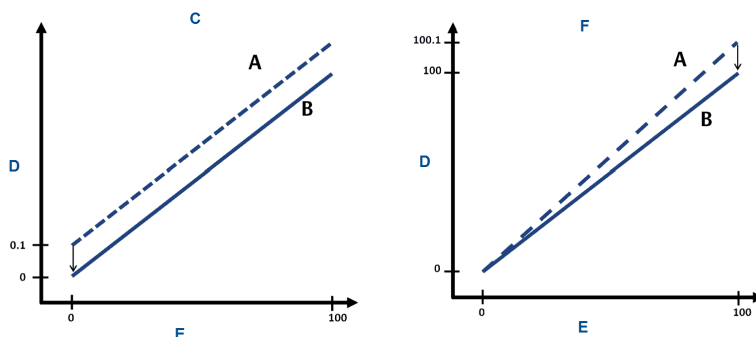

- A. Before trim
- B. After trim
- C. Zero/lower sensor trim
- D. Pressure reading
- E. Pressure input
- F. Upper sensor trim

## 6.4.2 Performing a sensor trim

When performing a sensor trim, you can trim both the upper and lower limits.

If performing both upper and lower trims, do the lower trim first.

### Note

Use a pressure input source that is at least four times more accurate than the transmitter and allow the input pressure to stabilize for 10 seconds before entering any values.

## Perform a sensor trim using a communication device

### Procedure

1. Navigate to the **Calibration** menu.
2. Select **Lower Sensor Trim**.

### Note

Select pressure points so that lower and upper values are equal to or outside the expected process operation range.

3. Follow the commands provided by the communication device to complete the adjustment of the lower value.
4. Repeat the procedure for the upper value, replacing **Lower Sensor Trim** with **Upper Sensor Trim** in [Step 2](#).

## 6.4.3 Recall Factory Trim - Sensor Trim

The `Recall Factory Trim - Sensor Trim` command allows the restoration of the as-shipped factory settings of the sensor trim.

This command can be useful for recovering from an inadvertent zero trim of an absolute pressure unit or inaccurate pressure source.

## Recall factory trim using a communication device

### Procedure

Go to **Device Settings** → **Calibration** → **Pressure** → **Factory Calibration** → **Restore Factory Calibration**.

## 6.5 Trimming the analog output

You can use the analog output trim command to adjust the transmitter's current output at the 4 and 20 mA points to match the plant standards.

[Figure 6-2](#) and [Figure 6-3](#) graphically show the two ways the characterization curve is affected when an analog output trim is performed.

**Figure 6-2: 4-20 mA Output Trim - Zero/Lower Trim**

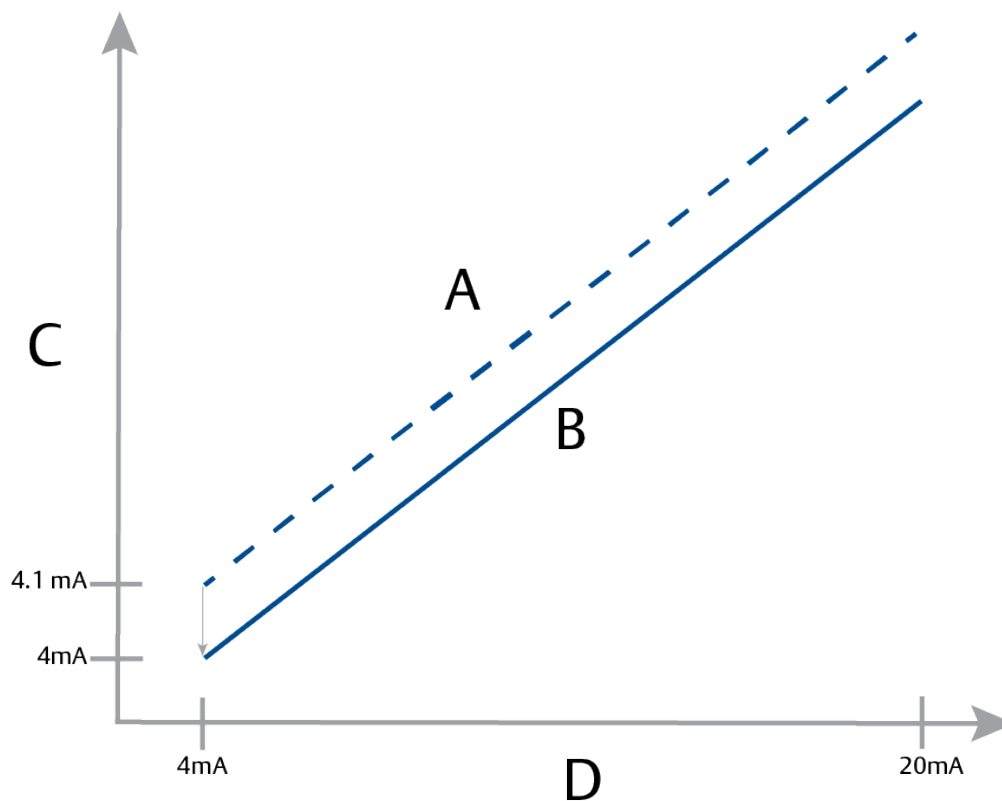

- A. Before trim
- B. After trim
- C. Pressure reading
- D. mA output

Figure 6-3: 4-20 mA Output Trim - Upper Trim

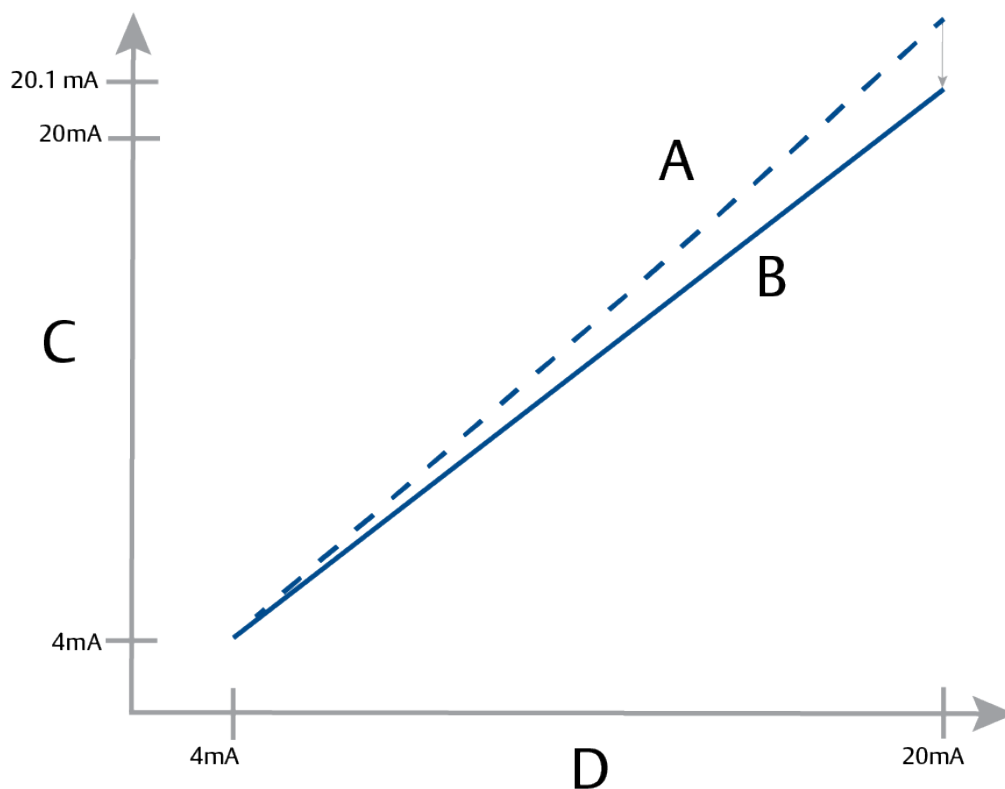

- A. Before trim
- B. After trim
- C. Pressure reading
- D. mA output

## 6.5.1 Performing digital-to-analog trim (4-20 mA output trim)

### NOTICE

If you add a resistor to the loop, ensure that the power supply is sufficient to power the transmitter to a 20 mA output, or Alarm state if using **High Alarm**, with additional loop resistance.

#### Related information

[Power supply for a 4–20 mA HART communication device](#)

### Perform a 4-20 mA output trim using a communication device

#### Procedure

Go to **Device Settings** → **Calibration** → **Analog Output** → **Calibration** → **Analog Calibration**.

## 6.5.2 Recalling factory trim - analog output

You can use the **Recall Factory Trim - Analog Output** command to restore the as-shipped factory settings to the analog output trim.

This command can be useful for recovering from an inadvertent trim, incorrect plant standard, or faulty meter.

### Recall factory trim - analog output using a communication device

#### Procedure

Go to **Device Settings** → **Calibration** → **Analog Output** → **Factory Output** → **Restore Analog Calibration**

## 6.6 Relay maintenance and operation (with output protocol code S)

### 6.6.1 Relay test

The relay test feature built in the transmitter allows you to test different states of the relay and ensure that the configured operation is working as intended for the specific application.

To find the relay test feature, navigate to the **Simulation** section of the user interface and select **Relay Test**.

### 6.6.2 Relay proof test

The relay proof test feature allows you to test the relay operation and then store the results in a proof test log.

The relay proof test feature is very similar to the simulated relay test except that you can enter a `Pass/Fail` result and custom notes tied to the test. You can use the proof testing feature to extend the maintenance interval of the relay switches.

To navigate to the relay proof test feature, go to **Device Settings** → **Calibration** → **Proof Test** → **Perform Proof Tests** → **Relay Proof Test**.



# 7 Troubleshooting

## 7.1 Troubleshooting overview

This chapter provides summarized troubleshooting suggestions for the most common operating problems.

## 7.2 Diagnostic messages

The following sections contain possible messages that appear on either the display, a communication device, or an AMS system. Use them to diagnose status messages.

- Failure ([Diagnostic message: Failure](#))
- Function Check ([Diagnostic message: Functional Check](#))
- Maintenance Required ([Diagnostic message: Maintenance required](#))
- Out of Specification ([Diagnostic message: Out of Specification](#))

### 7.2.1 Diagnostic message: Failure

Displayed status via HART® or Bluetooth® in **Software Tools**.

Alert label	Description	Recommended actions	Factory default setting	Factory or field configurable	Type of alert
Sensor Module Failure	A failure has been detected in the sensor module.	<ol style="list-style-type: none"> <li>1. Make sure that the cables between the sensor and electronics are securely connected.</li> <li>2. Replace the sensor module.</li> </ol>	Enabled	Factory	mA Alarm
Electronics Board Failure	A failure has been detected in the electronic circuit board.	Replace the electronic circuit board.	Enabled	Factory	mA Alarm
Incompatible Sensor Module	The electronic circuit board has detected a sensor module that is incompatible with the system.	Replace the incompatible sensor module.	Enabled	Factory	mA Alarm
Incompatible Terminal Block	The electronic circuit board has detected a terminal block that is incompatible with the system.	Replace the incompatible terminal block.	Enabled	Factory	mA Alarm

Alert label	Description	Recommended actions	Factory default setting	Factory or field configurable	Type of alert
Relay Terminal Block Not Installed	Process Alerts have been configured to use relays, but the electronic circuit board was unable to detect a terminal block with relays.	<ol style="list-style-type: none"> <li>1. Remove the wiring compartment cover (considering hazardous location requirements) and connect a terminal block with relay capability.</li> <li>2. Modify <b>Process Alerts</b> to use a notification mode which does not include relays.</li> </ol>	Enabled	Factory	mA Alarm
Terminal Block Failure	A failure has been detected in the terminal block.	<ol style="list-style-type: none"> <li>1. Replace the terminal block.</li> <li>2. Replace the electronic circuit board.</li> </ol>	Enabled	Factory	HART
Incompatible Hardware	The electronic circuit board has detected incompatible hardware components with the device's software version.	Remove the incompatible hardware component(s) connected to the device.	Enabled	Factory	HART
Sensor Communication Failure	The electronic circuit board has lost communication with the sensor module.	<ol style="list-style-type: none"> <li>1. Verify that the device is receiving adequate supply voltage.</li> <li>2. Remove the front housing cover (considering hazardous location requirements) and check the cable and cable connection between the sensor module and electronic circuit board.</li> <li>3. Replace the sensor module.</li> <li>4. Replace the electronic circuit board.</li> </ol>	Enabled	Factory	mA alarm

## 7.2.2 Diagnostic message: *Functional Check*

Displayed status via HART® or Bluetooth® in *Software Tools*.

Alert label	Description	Recommended actions	Factory default setting	Factory or field configurable	Type of alert
Loop Test Current Fixed	The analog output is fixed and does not represent the process measurement due to the device being set to Loop Test mode.	<ol style="list-style-type: none"> <li>1. Verify that loop test is no longer required.</li> <li>2. Disable loop test mode or restart the device.</li> </ol>	Enabled	Factory	HART
Primary Variable Simulated	The primary variable is being simulated and does not represent the process measurement.	<ol style="list-style-type: none"> <li>1. Verify that the <b>Primary Variable Simulation</b> is no longer required.</li> <li>2. Disable the <b>Primary Variable Simulation</b> or restart the device.</li> </ol>	Enabled	Factory	HART
Relay 1 Test State Fixed	The state of Relay 1 is fixed and is not being controlled by a <b>Process Alert</b> due to the relay being set to Relay Test mode.	<ol style="list-style-type: none"> <li>1. Verify that Relay Test is no longer required.</li> <li>2. Disable Relay Test mode or restart the device.</li> </ol>	Enabled	Factory	HART
Relay 2 Test State Fixed	The state of Relay 2 is fixed and is not being controlled by a <b>Process Alert</b> due to the relay being set to Relay Test mode.	<ol style="list-style-type: none"> <li>1. Verify that Relay Test is no longer required.</li> <li>2. Disable Relay Test mode or restart the device.</li> </ol>	Enabled	Factory	HART

## 7.2.3 Diagnostic message: *Maintenance required*

Displayed status via HART® or Bluetooth® in **Software Tools**.

Alert label	Description	Recommended actions	Factory default setting	Factory or field configurable	Type of alert
Loop Integrity Diagnostic	The <b>Loop Integrity</b> diagnostic has detected a deviation of the terminal voltage outside of configured limits. This may indicate degraded electrical or loop integrity.	<ol style="list-style-type: none"> <li>1. Check the DC power supply to make sure the power is correct, stable, and has minimal ripple.</li> <li>2. Check the loop wiring for degradation or improper grounding.</li> <li>3. Remove the wiring compartment cover (considering hazardous location requirements) and check for water or terminal block corrosion.</li> <li>4. Re-characterize loop and adjust the deviation limit if necessary.</li> </ol>	Disabled	Field	mA-Alarm or HART
Process Intelligence Diagnostic	The <b>Process Intelligence</b> diagnostic has detected a change in process noise levels that exceed the configured thresholds.	<ol style="list-style-type: none"> <li>1. Verify the conditions of the process where the device is installed.</li> <li>2. Adjust the alert thresholds if necessary.</li> </ol>	Disabled	Field	mA-Alarm or HART
Plugged Impulse Line Diagnostic	The <b>Plugged Impulse Line</b> diagnostic has a change of the process noise level, which indicates a plugged impulse line, a plugged flow element or a stirrer loss can be attributed.	<ol style="list-style-type: none"> <li>1. Verify the conditions of the process where the device is installed.</li> <li>2. Check the surrounding equipment and process for conditions stated above.</li> </ol>	Disabled	Field	mA-Alarm or HART
Relay Diagnostic	Relay diagnostics have detected a problem with relay power, wiring, or hardware	<ol style="list-style-type: none"> <li>1. Remove the wiring compartment cover (considering hazardous location requirements) and verify relays are wired correctly and that power has not been interrupted.</li> <li>2. Replace the terminal block.</li> </ol>	Enabled	Factory	HART

Alert label	Description	Recommended actions	Factory default setting	Factory or field configurable	Type of alert
Display Button Stuck	At least one button on the device display is stuck.	<ol style="list-style-type: none"> <li>1. Remove the front housing cover (considering hazardous location requirements) and ensure buttons are not depressed.</li> <li>2. If display buttons will not be used, disable the buttons.</li> <li>3. Replace the display.</li> </ol>	Enabled	Factory	HART
Display Communication Failure	The electronic circuit board has lost communication with the display note that the contents being displayed may not be correct.	<ol style="list-style-type: none"> <li>1. Remove the front housing cover (considering hazardous location requirements) and check that the display assembly is properly seated and connected to the electronic circuit board.</li> <li>2. Replace the display.</li> <li>3. Replace the electronic circuit board.</li> </ol>	Enabled	Factory	HART
Bluetooth Functionality Limited	The device is unable to send device data over Bluetooth due to an internal error. The device will continue to function independently of this Bluetooth alert.	<ol style="list-style-type: none"> <li>1. Remove the front housing cover (considering hazardous location requirements) and check that the display assembly is properly seated and connected to the electronic circuit board.</li> <li>2. Replace the display (which contains the bluetooth electronics).</li> </ol>	Enabled	Factory	HART
Bluetooth Electronics Error	Device internal diagnostics detected a Bluetooth electronics error. This error will likely result in reduced or no communication capability; however, the device will continue to function independently of this Bluetooth alert.	<ol style="list-style-type: none"> <li>1. Remove the front housing cover (considering hazardous location requirements) and replace the display (which contains the Bluetooth electronics), then restart the device.</li> </ol>	Enabled	Factory	HART
Process Alert 1	The device has detected a change in the monitored variable that exceeds the configured thresholds for Process Alert 1.	<ol style="list-style-type: none"> <li>1. Verify the monitored variable is beyond the alert values.</li> <li>2. Modify the alert settings or turn off alert.</li> </ol>	Disabled	Field	mA-Alarm or HART

Alert label	Description	Recommended actions	Factory default setting	Factory or field configurable	Type of alert
Process Alert 2	The device has detected a change in the monitored variable that exceeds the configured thresholds for Process Alert 2.	<ol style="list-style-type: none"> <li>1. Verify the monitored variable is beyond the alert values.</li> <li>2. Modify the alert settings or turn off alert.</li> </ol>	Disabled	Field	mA-Alarm or HART

## 7.2.4 Diagnostic message: Out of Specification

Displayed status via HART® or Bluetooth® in **Software Tools**.

Alert label	Description	Recommended actions	Factory default setting	Factory or field configurable	Type of alert
Pressure Out of Limits	The process pressure has exceeded the device's maximum measurement range.	<ol style="list-style-type: none"> <li>1. Verify the conditions of the process where the device is installed.</li> <li>2. Check the device pressure connection to make sure it is not plugged or isolating diaphragms are not damaged.</li> <li>3. Replace the sensor module.</li> </ol>	Enabled	Factory	HART
Module Temperature Out of Limits	The module temperature sensor has exceeded its normal operating range.	<ol style="list-style-type: none"> <li>1. Check the process and ambient temperatures to ensure they are within specifications.</li> <li>2. Replace the sensor module.</li> </ol>	Enabled	Factory	HART
Loop Current Saturated	The loop current is saturated due to the analog value being outside low or high saturation values, or the Primary Variable being saturated.	<ol style="list-style-type: none"> <li>1. Verify the conditions of the process where the device is installed.</li> <li>2. Verify the settings for the 4 mA and 20 mA range points and readjust if necessary.</li> <li>3. Check the device pressure connection to make sure it is not plugged or isolating diaphragms are not damaged.</li> <li>4. Replace the sensor module.</li> </ol>	Enabled	Factory	HART

## 7.3 Disassembling the transmitter

Disassembly of the transmitter may void hazardous location requirements.

### **⚠ WARNING**

#### **Explosion**

Explosions could result in death or serious injury.

Do not remove the instrument cover in explosive atmospheres when the circuit is live.

### 7.3.1 Remove from service

### **⚠ WARNING**

Follow all plant safety rules and procedures.

#### **Procedure**

1. Power down device.
2. Isolate and vent the process from the transmitter before removing the transmitter from service.
3. Remove all electrical leads and disconnect conduit.
4. Remove the transmitter from the process connection.
  - The Rosemount 4051S Coplanar™ Transmitter is attached to the process connection by four bolts and two cap screws. Remove the bolts and screws and separate the transmitter from the process connection. Leave the process connection in place and ready for reinstallation.
  - The 4051S In-Line Transmitter is attached to the process by a single hex nut process connection. Loosen the hex nut to separate the transmitter from the process. Do not wrench on neck of transmitter.
5. Clean isolating diaphragms with a soft rag and a mild cleaning solution, and rinse with clear water.

### **NOTICE**

Do not scratch, puncture, or depress the isolating diaphragms.

6. Whenever you remove the process flange or flange adapters, visually inspect the PTFE O-rings. Replace the O-rings if they show any signs of damage, such as nicks or cuts.

#### **Note**

You may reuse undamaged O-rings.

**Related information**

[Inline gauge transmitter orientation](#)

## 7.3.2 Remove terminal block

Electrical connections are located on the terminal block in the compartment labeled FIELD TERMINALS.

**Procedure**

1. Remove the housing cover from the field terminal side.
2. Loosen the three small screws located on the assembly in the 2 o'clock, 7 o'clock, and 10 o'clock positions relative to the top of the transmitter.
3. Pull the entire terminal block out to remove it.

**Related information**

[Safety information](#)

## 7.3.3 Remove electronics board

The transmitter electronics board is located in the compartment opposite the terminal side.

**Procedure**

1. Remove the housing cover opposite the field terminal side.
2. If you are disassembling a transmitter with an LCD display, loosen the two captive screws that are visible on the front of the LCD display.  
The two screws anchor the LCD display to the electronics board and the electronics board to the housing.

---

**Note**

The electronics board is electrostatically sensitive; observe handling precautions for static-sensitive components.

---

**Note**

If an LCD display is installed, use caution as there is an electronic pin connector that interfaces between the LCD display and electronics board.

---

## 7.3.4 Remove sensor module from electronics housing

**Procedure**

1. Remove the housing cover opposite the field terminal side.
2. If you are disassembling a transmitter with an LCD display, loosen the two captive screws that are visible on the front of the LCD display.  
The two screws anchor the LCD display to the electronics board and the electronics board to the housing.
3. Pull out the electronics board and locate the connection to the sensor module.
4. Grasp the module connector and push in the two tabs at the point where they meet the module and pull upwards (avoid pulling wirings).  
You may need to rotate housing to access locking tabs.

5. Using a 1/8-inch hex wrench, loosen the housing rotation set screw one full turn.
6. Unscrew the module from the housing.

**Related information**

[Remove electronics board](#)

## 7.4 Reassembly procedures

**Note**

The V-seal must be installed at the bottom of the housing.

### 7.4.1 Attach sensor module to housing

**Procedure**

1. Apply a light coat of low temperature silicon grease to the sensor module threads and O-ring.
2. Thread the housing completely onto the sensor module.

**⚠ WARNING**

The housing must be no more than one full turn from flush with the sensor module to comply with explosion-proof requirements.

3. Tighten the housing rotation set screw using a 3/32-inch hex wrench.

### 7.4.2 Install the electronics board assembly in the housing

**Procedure**

1. Apply a light coat of low temperature silicon grease to the sensor module connector.
2. Insert the sensor module connector into the top of the sensor module.
3. Gently slide the assembly into the housing, ensuring the pins from the housing properly engage the receptacles on the assembly.
4. Tighten the captive mounting screws.
5. Attach the housing cover and tighten so that metal contacts metal to meet explosion-proof requirements.

**Postrequisites**

When installing a new electronics board, it is important to verify the device configuration and perform a loop test prior to operation.

### 7.4.3 Install terminal block

#### Install terminal block in housing

**Procedure**

1. Gently slide the terminal block into the housing, making sure the pins from the housing properly engage the receptacles on the terminal block.

2. Tighten the captive screws on the terminal block to a torque between 10 and 15 in-lb.
3. Attach the housing cover and tighten so that metal contacts metal to meet explosion-proof requirements.

## 7.4.4 Reassemble process flange

### Procedure

1. Inspect sensor module PTFE O-rings.  
If O-rings are undamaged, Emerson recommends reusing them. If the O-rings are damaged (if they have nicks or cuts, for example), replace them with new O-rings.

#### NOTICE

When replacing O-rings, be careful not to scratch or deface the O-ring grooves or the surface of the isolating diaphragm when removing the damaged O-rings.

2. Install the process flange on the sensor module. To hold the process flange in place, install the two alignment screws to finger-tight (screws are not pressure retaining).

#### NOTICE

Do not overtighten; this will affect module-to-flange alignment.

3. Install the appropriate flange bolts:
  - a) If the installation requires a ¼–18 NPT connection(s), use four 1.75 inch flange bolts. Go to [Step d](#).
  - b) If the installation requires a ½—14 NPT connection(s), use four 2.88 inch process flange/adaptor bolts. For gauge pressure configurations, use two 2.88 inch bolts and two 1.75 inch bolts. Go to [Step c](#).
  - c) Hold the flange adapters and adaptor O-rings in place while finger-tightening the bolts.
  - d) Finger-tighten the bolts.
4. Tighten the bolts to the initial torque value using a crossed pattern.  
See [Table 7-1](#) for appropriate torque values.
5. Tighten the bolts to the final torque value using a crossed pattern. When fully tightened, the bolts should extend through the top of the module housing. If the installation uses a conventional manifold, install flange adapters on the process end of the manifold using the 1.75 inch flange bolts supplied with the transmitter.

**Table 7-1: Bolt Installation Torque Values**

Bolt material	Initial torque value	Final torque value
Carbon steel (CS)-ASTM-A449 Standard	300 in-lb (34 N-m)	650 in-lb (73 N-m)
316 stainless steel (SST)—Option L4	150 in-lb (17 N-m)	300 in-lb (34 N-m)
ASTM-A-193-B7M—Option L5	300 in-lb (34 N-m)	650 in-lb (73 N-m)

**Table 7-1: Bolt Installation Torque Values (continued)**

Bolt material	Initial torque value	Final torque value
Alloy K-500 —Option L6	300 in-lb (34 N-m)	650 in-lb (73 N-m)
ASTM-A-453-660—Option L7	150 in-lb (17 N-m)	300 in-lb (34 N-m)
ASTM-A-193-B8M—Option L8	150 in-lb (17 N-m)	300 in-lb (34 N-m)

6. If you replaced the PTFE sensor module O-rings, re-torque the flange bolts after installation to compensate for cold flow.
7. Install the drain/vent valve:
  - a) Apply sealing tape to the threads on the seat. Starting at the base of the valve with the threaded end pointing toward the installer, apply two clockwise turns of sealing tape.
  - b) Take care to place the opening on the valve so that process fluid will drain toward the ground and away from human contact when the valve is opened.
  - c) Tighten the drain/vent valve to 250 in-lb (28.25 N-m).

#### Postrequisites

After replacing O-rings on Range 1 Transmitters and re-installing the process flange, expose the transmitter to a temperature of 185 °F (85 °C) for two hours. Then re-tighten the flange bolts in a cross pattern, and again expose the transmitter to a temperature of 185 °F (85 °C) for two hours before calibration.



## 8 Safety Instrumented Systems (SIS)

The safety-critical output of the Rosemount 4051S Pressure Transmitter is provided through a 2-wire, 4–20 mA signal representing pressure. The 4051S safety-certified pressure transmitter is certified to:

- Low and high demand: Type B element
- Route 2H, low demand application: Safety Integrity Level (SIL) 2 for random integrity at HFT=0, SIL3 for random integrity at HFT=1
- Route 2H, high demand application: SIL2 and SIL3 for random integrity at HFT=1
- Route 1H where the SFF  $\geq$  90 percent: SIL2 for random integrity at HFT=0, SIL3 for random integrity at HFT=1
- SIL3 for systematic integrity

### 8.1 Rosemount 4051S safety certified identification

All 4051S transmitters must be identified as safety certified before installing into Safety Instrumented Systems (SIS).

#### Procedure

1. Check NAMUR Software Revision located on the metal device tag: SW\_ . \_ . \_ .  
For more details on device revisions, refer to [NAMUR NE53 Device Revision History at NAMUR NE-53 Documentation for Measurement Instruments](#).
2. Verify that the option code QT is included in the transmitter model code.
3. Devices used in safety applications with ambient temperatures below -40 °F (-40 °C) require option codes QT and BR5 or BR6.

### 8.2 Installation in Safety Instrumented Systems (SIS) applications

#### **⚠ WARNING**

Installations must be performed by qualified personnel.

No special installation is required in addition to the standard installation practices outlined in the applicable product manual.

#### **⚠ WARNING**

Always ensure a proper seal by installing the electronics housing cover(s) so that metal contacts metal if housing is used.

See the *Specifications* section of the [Rosemount 4051S Pressure Transmitter Product Data Sheet](#) for environmental and operational limits.

The loop should be designed so the terminal voltage does not drop below 11.5 Vdc for the Rosemount 4051S when the transmitter output is 23.0 mA.

Set the **Security** switch to ON to prevent accidental or deliberate change of configuration data during normal operation.

## 8.3 Configuring in Safety Instrumented Systems (SIS) applications

Use any HART®-capable configuration tool to communicate with and verify configuration of the transmitter.

### ⚠ WARNING

Transmitter output is not safety-rated during the following: configuration changes, multidrop, and loop test. Use alternative means to ensure process safety during transmitter configuration and maintenance activities.

## 8.4 Damping

User-selected **damping** will affect the transmitter's ability to respond to changes in the applied process. The **damping** value and response time must not exceed the loop requirements.

## 8.5 Alarm and saturation levels

Configure a distributed control system (DCS) or safety logic solver to match transmitter configuration.

The following three figures identify the various alarm levels available and their operations values.

Figure 8-1: Rosemount Alarm Level

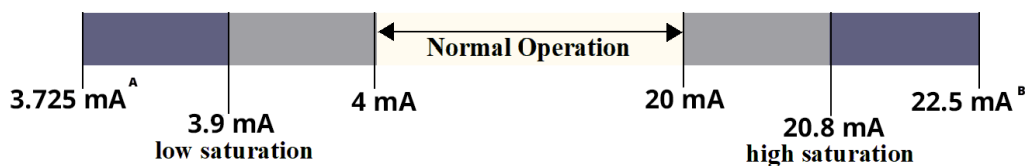

A. Transmitter failure, hardware or software alarm in Low position.

B. Transmitter failure, hardware or software alarm in High position.

Figure 8-2: NAMUR Alarm Level

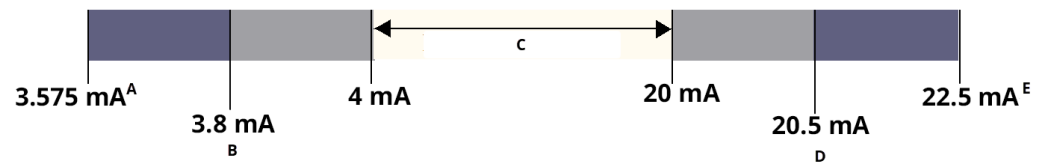

- A. Transmitter failure, hardware or software alarm in Low position.
- B. Low saturation
- C. Normal operation
- D. High saturation
- E. Transmitter failure, hardware or software alarm in High position.

Figure 8-3: Custom Alarm Level

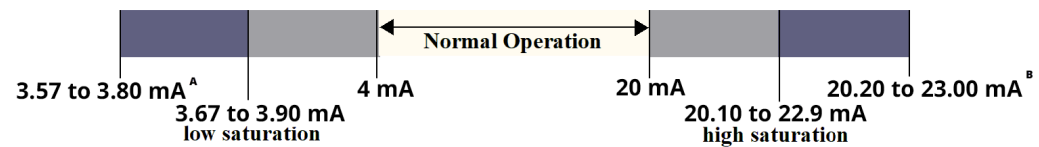

Low alarm must be at least 0.1 mA lower than the low saturation value.

- A. Transmitter failure, hardware or software alarm in Low position.
- B. Transmitter failure, hardware or software alarm in High position.

Setting the alarm values and direction varies depending on whether the Hardware Switch, included with option code S, is installed. You can use a HART® master or communicator to set the **Alarm** and **Saturation** values.

## 8.6 Safety Instrumented Systems (SIS) operation and maintenance

### 8.6.1 Proof tests

Emerson recommends the following proof tests. In the event that an error is found in the safety and functionality, proof test results and corrective actions taken can be documented at [Contact Measurement Instrumentation Solutions Customer Service](#).

#### **⚠ WARNING**

All proof test procedures must be carried out by qualified personnel.

Use a communication device to perform a loop test, analog output trim, or sensor trim. **Security** switch should be in the unlocked position during proof test execution and repositioned in the locked position after execution.



## 8.6.4 Comprehensive proof test

The comprehensive proof test consists of performing the same steps as the simple suggested proof test, but with a two point verification of the pressure sensor.

See the Failure Modes, Effects and Diagnostics Analysis Report for percent of possible DU failures in the device.

**Required tools:**

- Communication device
- mA meter
- Pressure calibration equipment

### Procedure

1. Bypass the safety function and take appropriate action to avoid a false trip.
2. Use HART® communication to retrieve any diagnostics and take appropriate action.
3. Send a HART command to the transmitter to go to the high alarm current output and verify that the analog current reaches that value.
4. Send a HART command to the transmitter to go to the low alarm current output and verify that the analog current reaches that value.
5. Perform a two-point verification of the sensor over the full working range and verify the current output at each point.
6. Remove the bypass and otherwise restore normal operation.
7. Place the security switch in the locked position.

The user determines the proof test requirements for impulse piping.

### Note

Automatic diagnostics are defined for the corrected % DU: The tests performed internally by the device during run time without requiring enabling or programming by the user.

## 8.7 Inspection

### 8.7.1 Product repair

The Rosemount 4051S is repairable by major component replacement.

All failures detected by the transmitter diagnostics or by the proof-test must be reported. Feedback can be submitted electronically at [Emerson.com/Measurement-Instrumentation/Safety-Measurement](https://www.emerson.com/Measurement-Instrumentation/Safety-Measurement).

### **⚠ WARNING**

All product repair and part replacement must be performed by qualified personnel.

### 8.7.2 Rosemount 4051S SIS reference

The 4051S must be operated in accordance to the functional and performance specifications provided in [Reference data](#).

## 8.7.3 Specifications

The transmitter must be operated according to the functional performance specifications provided in the [Rosemount 4051S Pressure Transmitter Product Data Sheet](#).

### Failure rate data

The *Failure Mode, Effects, and Diagnostic Analysis (FMEDA) Report* includes failure rates and independent information on generic sensor modules.

### Failure values

Safety deviation, the percent a failure could drift to be defined as safe/dangerous failure, is  $\pm 2$  percent.

Transmitter response time: 80 milliseconds. See also *Specifications* section of the [Rosemount 4051S Pressure Transmitter Product Data Sheet](#) and [Damping](#) to take into account additional response time due to damping configuration.

The switch output response time will be up to 1 second or the time delay setting for the process alert that is configured to drive the switch output.

Self-diagnostics test interval: at least once every 60 minutes.

### Product life

50 years - Based on worst case component wear-out mechanisms; not based on wear-out of process sensors.

## A Reference data

### A.1 Ordering information, specifications, and drawings

To view current Rosemount 4051S ordering information, specifications, and drawings, follow these steps:

#### Procedure

1. Go to [Emerson.com/global](https://www.emerson.com/global) and search for "Rosemount 4051S".
2. Scroll as needed to the green menu bar and click **Documents & Drawings**.
3. For installation drawings, click **Drawings & Schematics** and select the appropriate document.
4. For ordering information, specifications, and dimensional drawings, click **Data Sheets & Bulletins** and select the appropriate Product Data Sheet.
5. For the Declaration of Conformity, click **Certificates & Approvals** and select the most current document.

### A.2 Product Certifications

To view current Rosemount 4051S product certifications, click **Documents & Drawings** and see the [Rosemount 4051S Pressure Transmitter Quick Start Guide](#).



# B Device Driver (DD) menu trees

Figure B-1: Menu Trees Overview

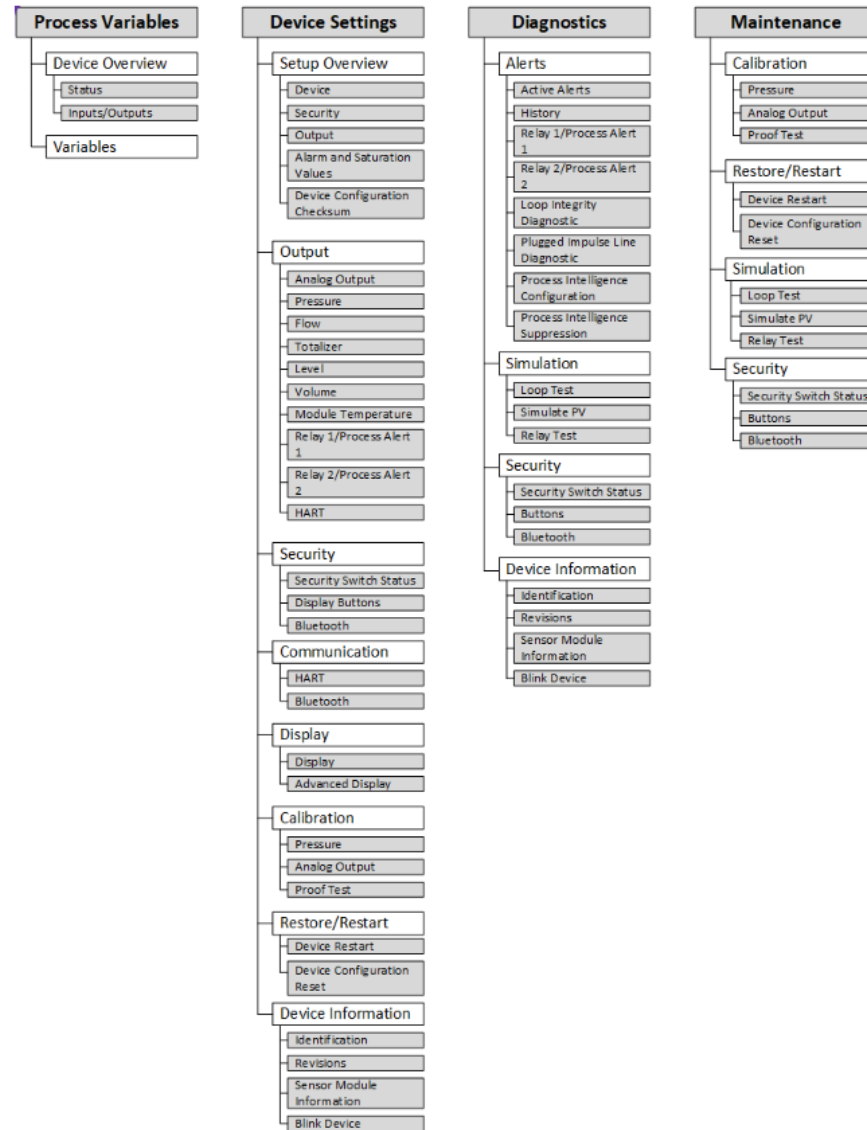

Figure B-2: Process Variables menu

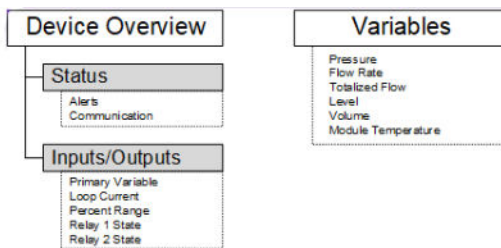

Figure B-3: Device Settings 1

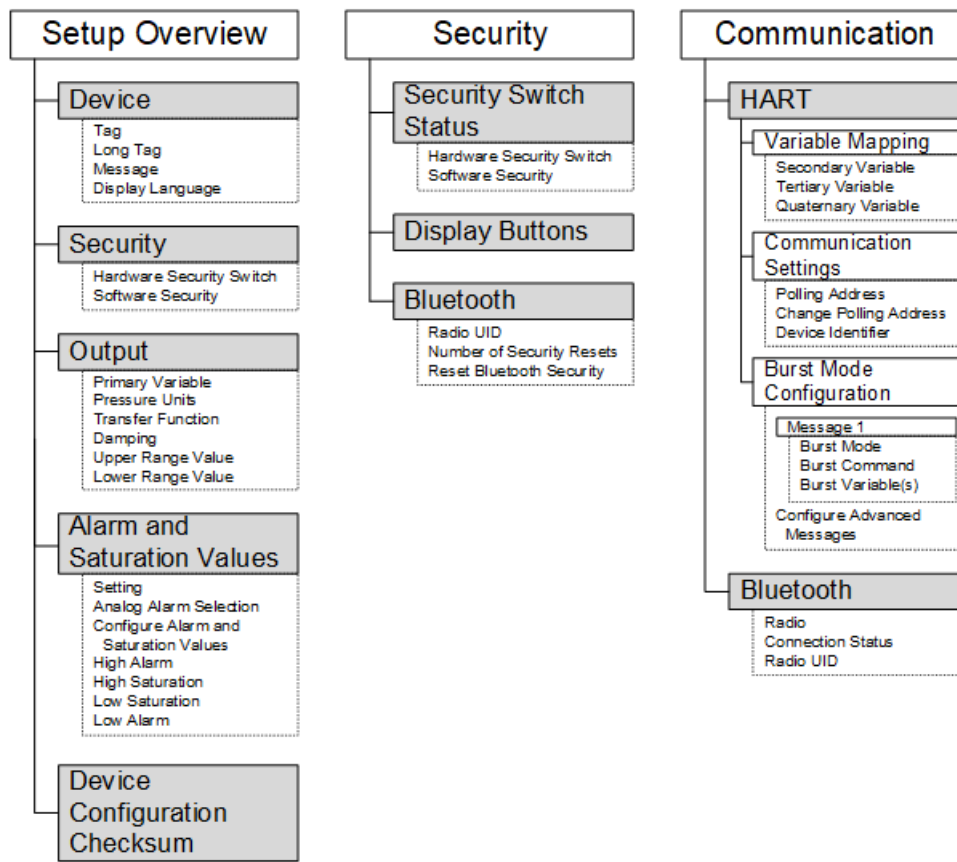

Figure B-4: Device Settings 2

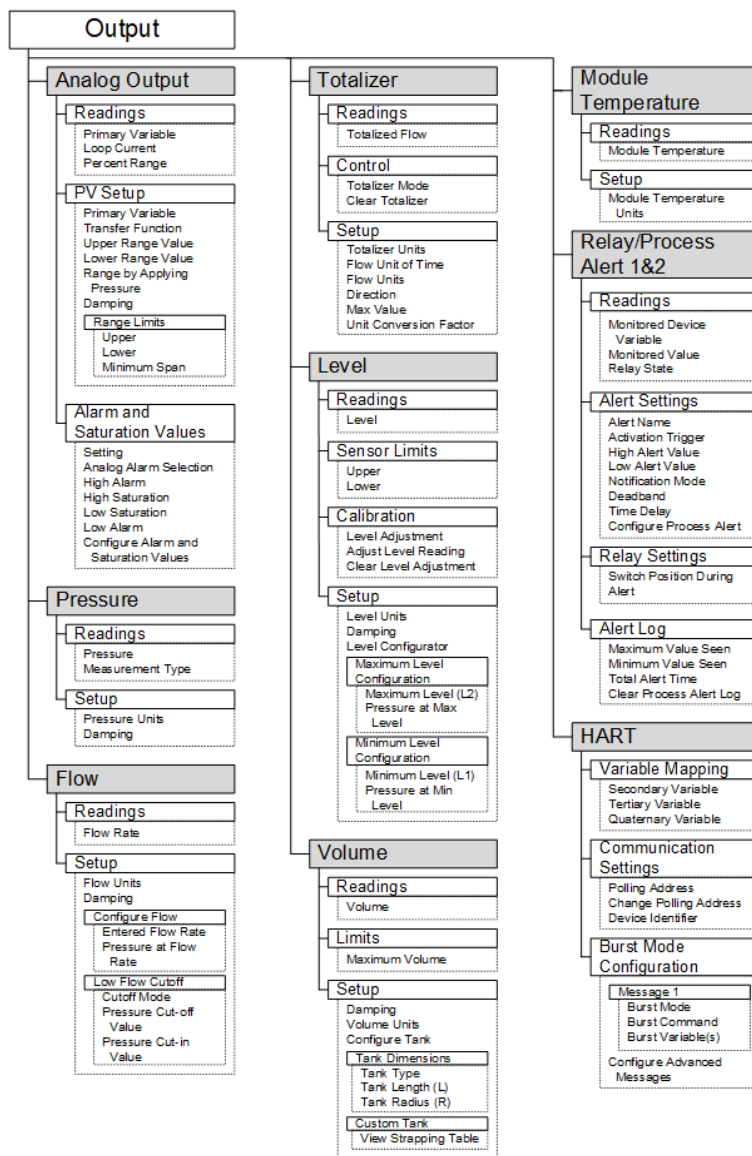

Figure B-5: *Device Settings 3*

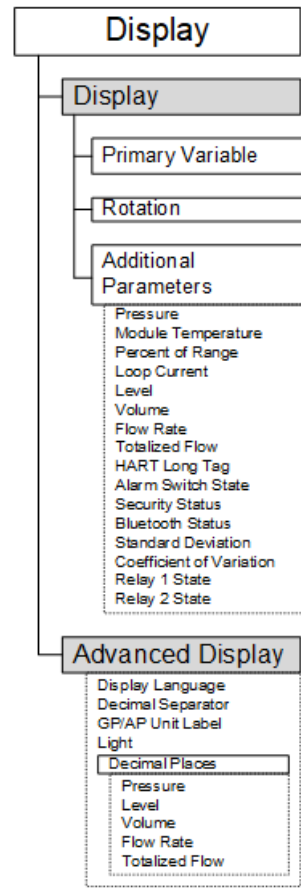

Figure B-6: Device Settings 4

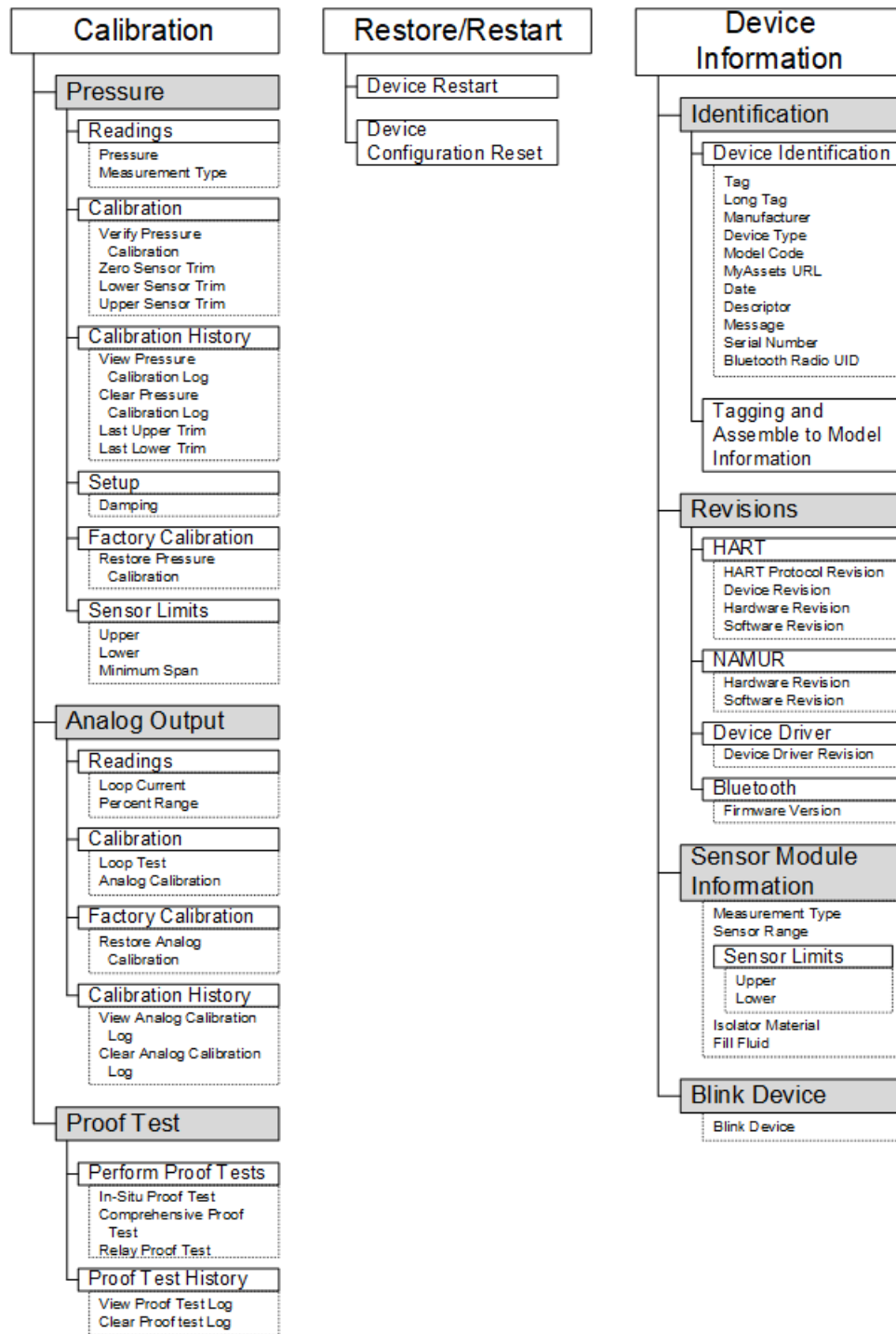

Figure B-7: *Diagnostics 1*

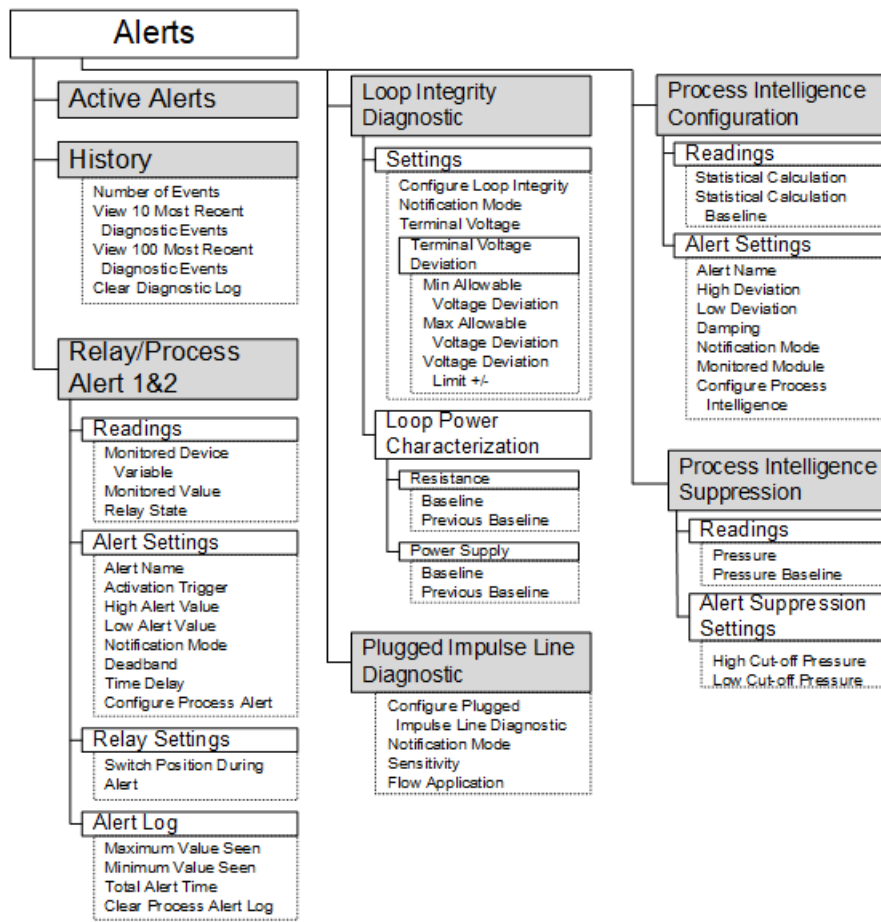

Figure B-8: *Diagnostics 2*

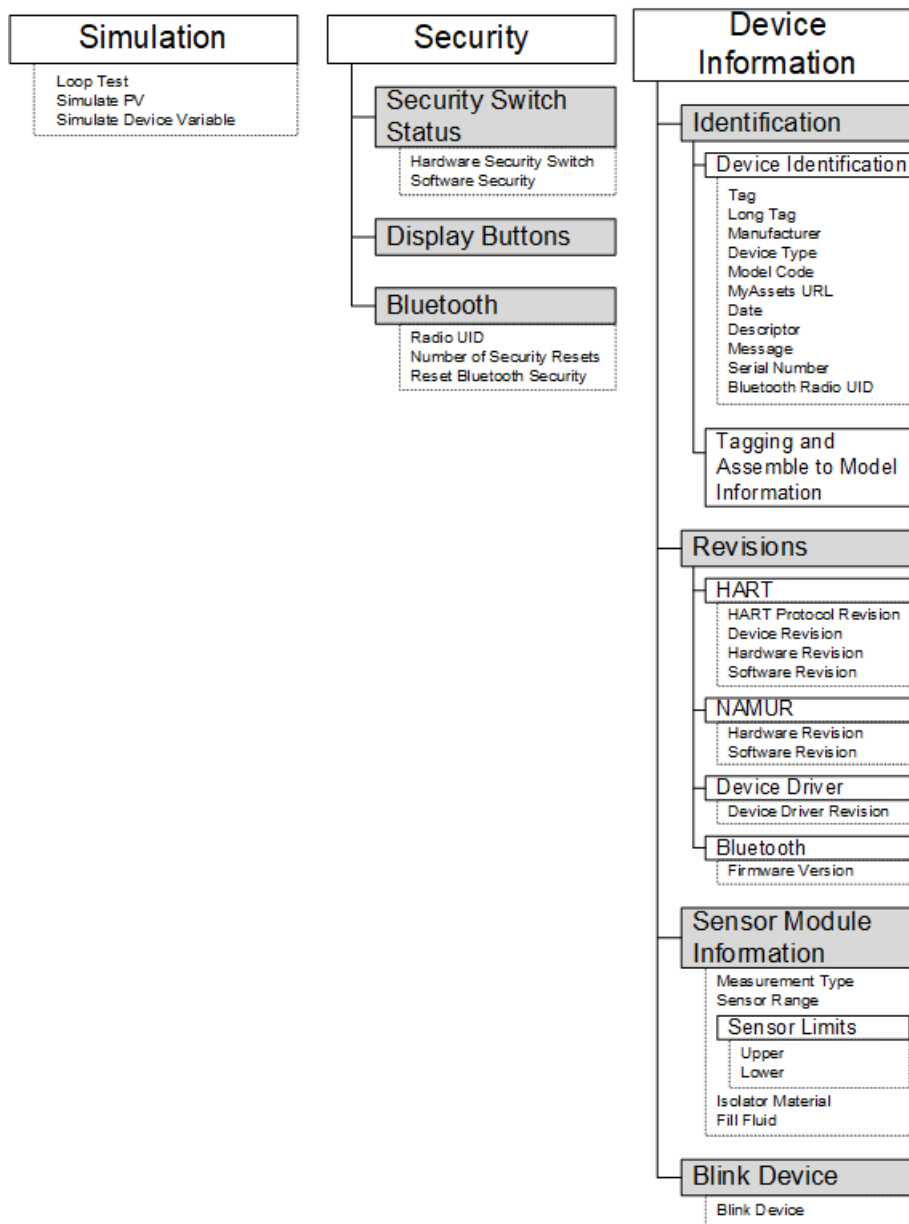

Figure B-9: Maintenance 1

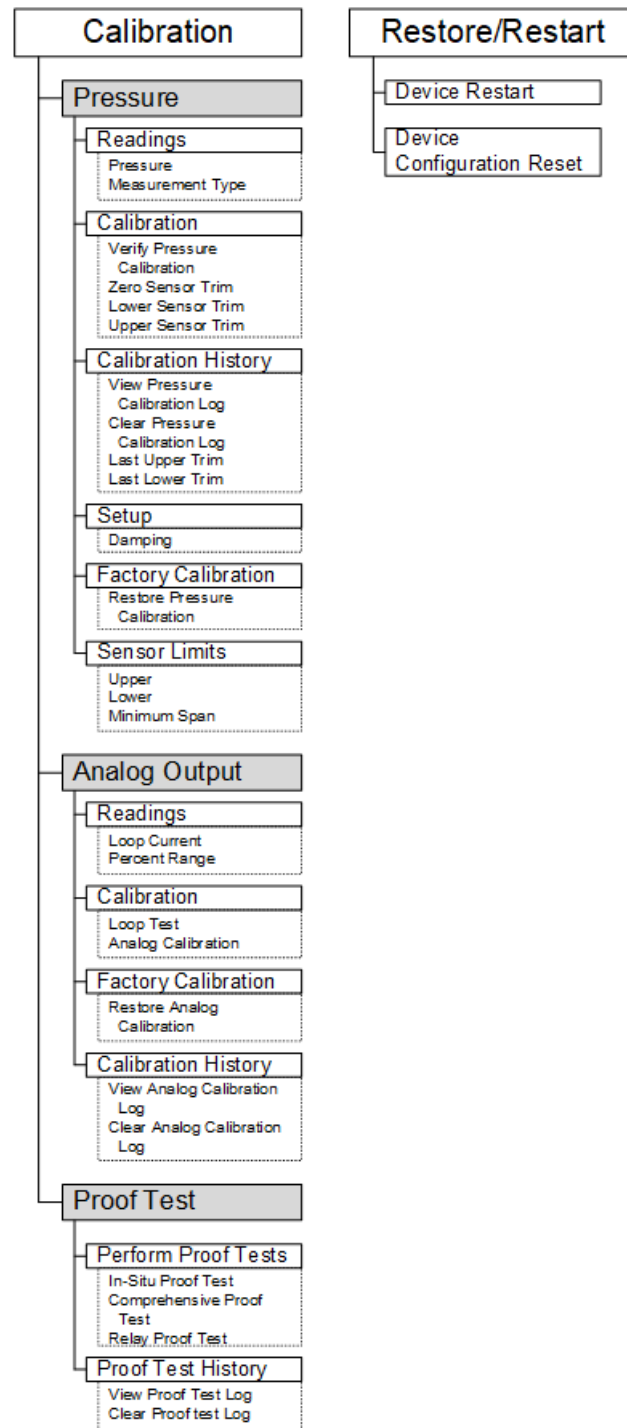
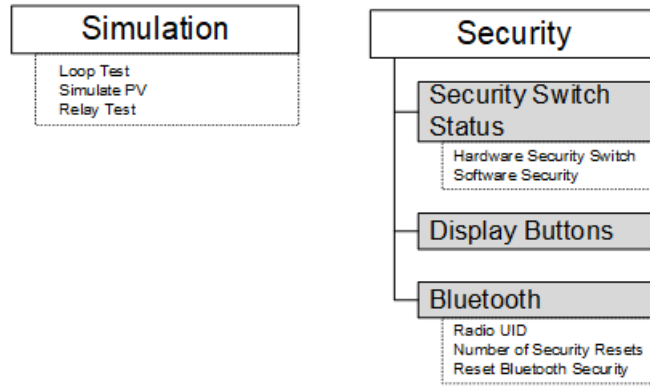

Figure B-10: Maintenance 2





## C Quick Service buttons

Menu title	Button
<i>View Config</i>	PV (Primary Variable)
	PV Damping
	PV Upper Range Value (URV)
	PV Lower Range Value (LRV)
	AO Alarm (Analog Output)
	HI (High) Saturation
	LO (Low) Saturation
<i>Zero</i>	Trim to PV Zero
	Set current reading as 4 mA
<i>Rerange</i>	Set 4 mA
	Set 20 mA
<i>Loop Test</i>	Set 4 mA
	Set 8 mA
	Set 12 mA
	Set 16 mA
	Set 20 mA
<i>Rotate Disp</i>	Rotate 90-degree increments

For more information: [Emerson.com/global](https://emerson.com/global)

©2026 Emerson. All rights reserved.

Emerson Terms and Conditions of Sale are available upon request. The Emerson logo is a trademark and service mark of Emerson Electric Co. Rosemount is a mark of one of the Emerson family of companies. All other marks are the property of their respective owners.

The "Bluetooth" word mark and logos are registered trademarks owned by Bluetooth SIG, Inc. and any use of such marks by Emerson is under license.