

Rosemount™ 4051S Pressure Transmitters

with 4-20 mA HART® Protocol



Product documents can be located by selecting the search tool magnifier icon at the top of www.emerson.com and then select the "Serial Number" lookup button in the pop-up menu.

For Additional Product Information:

Please scan the QR code on this document for your local language safety messages. Escaneie o código QR acima para obter as mensagens de segurança no idioma local. Bitte scannen Sie den QR-Code oben nach den Sicherheitshinweisen Ihrer Landessprache.

Veuillez scanner le code QR ci-dessus pour obtenir vos messages de sécurité en langue locale.

Lea el código QR anterior para ver sus mensajes de seguridad en el idioma local. Eseguire la scansione del codice QR sopra indicato per i messaggi di sicurezza nella lingua locale.

Отсканируйте QR-код выше, чтобы получить сообщения о безопасности на местном языке.

请扫描上面的 QR 代码以了解您的本地语言安全消息。上記の QR コードをスキャンして、地域の言語の安全性に関するメッセージを確認してください。

현재 언어 안전 메시지를 보려면 위의 QR 코드를 스캔하세요

ROSEMOUNT™



EMERSON™

WARNING

Read this document before working with the product. For personal and system safety and for optimum product performance, ensure that you thoroughly understand the contents before installing, using, and maintaining the product.

Failure to follow safe installation and servicing guidelines could result in death or serious injury.

Ensure the transmitter is installed by qualified personnel and in accordance with applicable code of practice. Use the transmitter only as specified in the product manual. Failure to do so may impair the protection provided by the transmitter.

Repair, e.g. substitution of components, etc. may jeopardize safety and is under no circumstances allowed. Unauthorized changes to the product are strictly prohibited, as they may unintentionally and unpredictably alter performance and jeopardize safety. Unauthorized changes that interfere with the integrity of the welds or flanges, such as making additional perforations, compromise product integrity and safety. Equipment ratings and certifications are no longer valid on any products that have been damaged or modified without the prior written permission of Emerson. Any continued use of product that has been damaged or modified without the written authorization is at the customer's sole risk and expense.

Explosions

Explosions could result in death or serious injury.

Installation of this transmitter must be in accordance with the appropriate local, national, and international standards, codes, and practices. Review the hazardous locations certifications for any restrictions associated with a safe installation.

When cover is removed, protect the interior of the transmitter from external contamination exceeding that of a Pollution Degree 2 environment.

Process leaks

Process leaks may cause harm or result in death.

Install and tighten process connectors before applying pressure. Do not remove while in operation.

Electrical shock

Electrical shock can result in death or serious injury.

Avoid contact with the leads and terminals. High voltage that may be present on leads can cause electrical shock. Ensure the power to the transmitter is off and the lines to any other external power source are disconnected or not powered while wiring the transmitter. Ensure the wiring is suitable for the electrical current and the insulation is suitable for the voltage, temperature, and environment.

Keep cover closed while circuit is live.

Avertissement

Gardez le couvercle fermé pendant que le circuit est sous tension.

After de-energizing, wait 2 minutes before opening.

Avertissement

Après la mise hors tension, attendre 2 minutes avant d'ouvrir.

Substitution of components may impair intrinsic safety.

Avertissement

La substitution de composants peut compromettre la sécurité intrinsèque.

Explosion hazard

Substitution of components may impair suitability for Class I, Division 2.

Avertissement - Risque d'explosion

La substitution de composants peut rendre ce matériel inacceptable pour les emplacements de Classe I, Division 2.

Physical access

Unauthorized personnel may potentially cause significant damage to and/or misconfiguration of end users' equipment. This could be intentional or unintentional and needs to be protected against.

Physical security is an important part of any security program and fundamental in protecting your system. Restrict physical access by unauthorized personnel to protect end users' assets. This is true for all systems used within the facility.

CAUTION

Unless marked, the conduit/cable entries in the housing use a ½–14 NPT thread form. Entries marked **M20** are M20 × 1.5 thread form. On devices with multiple conduit entries, all entries will have the same thread form. Only use plugs, adapters, glands, or conduit with a compatible thread form when closing these entries.

When installing in a hazardous location, use only appropriately listed or Ex-certified plugs, glands, or adapters in cable/conduit entries.

Before use, check the cable glands and blanking plugs are suitably rated.

Isolate supply before connecting the transmitter or removing the electronics.

Note



The **Protective Earth** terminal must be connected to an external earthing system when **Switch Output (S)** option is included.

General

NOTICE

Installation in classified locations may be subject to additional installation requirements. See the associated installation drawing.

When multiple types of protection are present on a label, only one type may be selected for installation. The user shall permanently mark the type of protection chosen for the specific installation. Once the type of protection has been marked, it shall not be changed.

Maintenance in classified locations may be restricted, limited, and/or subject to additional requirements. Refer to the associated installation drawing.

NOTICE

Supply wiring requirements

Use twisted pairs to yield best results. To ensure proper communication, use the 24 to 14 AWG wire. Twisted pairs and shielded wiring are recommended for environments with high EMI (electromagnetic interference). Two wires can be safely connected to each terminal screw. Do not exceed 5,000 ft. (1,500 m).

Determine local wiring and conduit requirements. Understand local wiring and conduit requirements prior to installation and be sure to follow all regulations during the transmitter's installation.

1 About this guide

This guide provides basic installation guidelines for Rosemount 4051S Transmitters.

It does not provide instructions for configuration, diagnostics, maintenance, troubleshooting, explosion-proof, flameproof, or intrinsically safe (IS) installations. Refer to the *Rosemount 4051S Pressure Transmitter Manual* for more instructions.

This guide and the referenced manual are also available electronically at Emerson.com.

2 General safety certificates and approvals

See [Product certifications](#) for approvals information.

Product certifications are also in the online version of this Quick Start Guide on Emerson.com.

3 Mounting the transmitter

For dimensional drawings, refer to the *Documents* section on Rosemount 4051S Pressure Transmitter.

WARNING

Process connection temperatures above 185 °F (85 °C) require a limited ambient temperature, reduced by a 1:15 ratio. Consider process connection and ambient temperatures when installing the transmitter with hazardous location certifications. See [Table 3-1](#).

Table 3-1: Intrinsically safe/increased safety

Process connection temperature	Maximum ambient temperature
-76 to +185 °F (-60 to +85 °C)	158 °F (70 °C)
185 to 250 °F (85 to 121 °C)	158 to 60 °F (70 to 16 °C) ⁽¹⁾

(1) Maximum ambient temperature is reduced by 1.5 degree for 1 degree temperature rise in the process connection temperature beyond 185 °F (85 °C).

3.1 Using a mounting bracket

Refer to the *Rosemount 4051S Pressure Transmitter Manual* on [Rosemount 4051S Pressure Transmitter](#) for images and instructions on how to properly mount the transmitter using the mounting brackets provided by Emerson.

NOTICE

Use only bolts provided with the transmitter or sold as Emerson spare parts. Tighten bolts to a torque of 125 in-lb.

3.2 Install bolts

If the transmitter installation requires assembly of a process flange, manifold, or flange adapters, follow assembly guidelines to ensure a tight seal for optimal performance characteristics of the transmitter.

Figure 3-1 illustrates common transmitter assemblies with the bolt length required for proper transmitter assembly.

Figure 3-1: Common transmitter assemblies

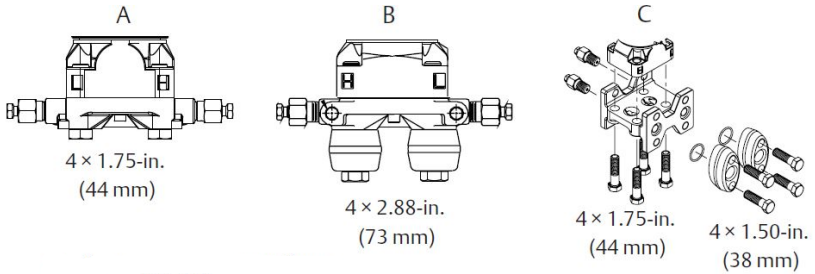

A. Transmitter with Coplanar™ flange

B. Transmitter with Coplanar flange and optional flange adapters









C. Transmitter with traditional flange and optional flange adapters

Note

For all other assemblies, refer to the related manual or contact Rosemount Customer Central technical support.

Carbon steel bolts do not require lubrication, and stainless steel bolts are coated with a lubricant to ease installation. Do not apply additional lubricant when installing either type of bolt.

Table 3-2: Torque values for the flange and flange adapter bolts

Bolt material	Head markings	Initial torque	Final torque
Carbon steel (CS)	 	300 in-lb.	650 in-lb.
Stainless steel (SST)	  	150 in-lb.	300 in-lb.
	  		

1. Finger-tighten the bolts.
2. Torque the bolts to the initial torque value using a crossing pattern. Then, torque the bolts to the final torque value using the same crossing pattern. See Table 3-2 for initial and final torque values.

3. Verify the flange bolts are protruding through the sensor module before applying pressure.

3.3 Mounting requirements

Impulse piping configurations depend on specific measurement conditions. Refer to [Figure 3-2](#) for examples of the following mounting configurations:

3.3.1 Liquid measurement

- Place taps to the side of the line to prevent sediment deposits on the transmitter's process isolators.
- Mount the transmitter beside or below the taps so gases can vent into the process line.
- Mount drain/vent valve upward to allow gases to vent.

3.3.2 Gas measurement

- Place taps in the top or side of the line.
- Mount the transmitter beside or above the taps so liquid will drain into the process line.

3.3.3 Steam measurement

- Place taps to the side of the line.
- Mount the transmitter below the taps to ensure that the impulse piping will stay filled with condensate.
- In steam service above 250 °F (121 °C), fill impulse lines with water to prevent steam from contacting the transmitter directly and to ensure accurate measurement start-up.

NOTICE

For steam or other elevated temperature services, it is important that temperatures at the process connection do not exceed the transmitter's process temperature limits.

Figure 3-2: Installation examples

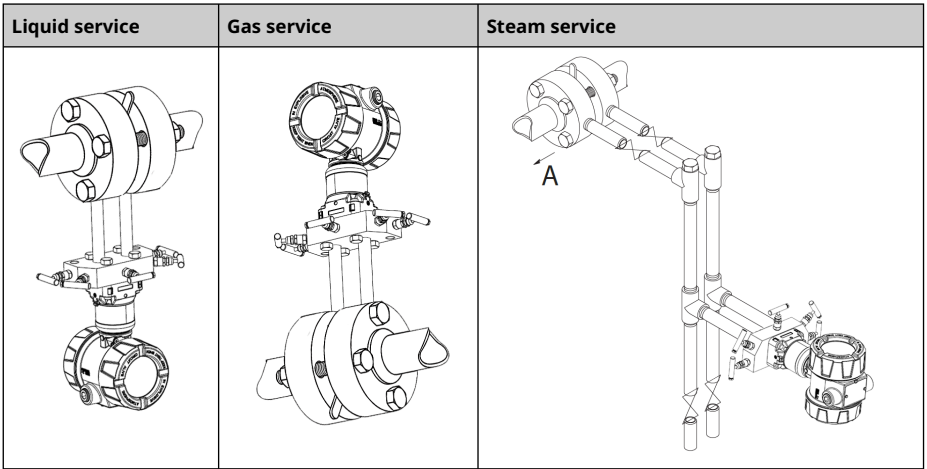

A. Flow

For additional mounting best practices, refer to the *Rosemount 4051S Pressure Transmitter Manual* on [Rosemount 4051S Pressure Transmitter](#).

3.4 O-rings with flange adapters

WARNING

Process leaks

Process leaks could result in death or serious injury.

To avoid process leaks, only use the O-ring designed to seal with the corresponding flange adapter.

3.5 In-line gauge transmitter orientation

The low side pressure port (atmospheric reference) on the in-line gauge transmitter is located under the sensor module neck label.

Keep the vent path free of any obstruction, including but not limited to paint, dust, and lubrication, by mounting the transmitter so that any contaminants can drain away.

3.6 Rotate housing

To improve field access to wiring or to better view the optional LCD display:

NOTICE

Over-rotation may sever the electrical connection between the sensor module and the electronics.

Do not rotate the housing more than 180° without first disassembling the transmitter.

1. Loosen the external 1/8-inch housing rotation set screw located on the side of the transmitter housing below the conduit entry and near the (option) external ground.
2. Turn the housing up to 180° left or right of its original (as shipped) position.
3. Re-tighten the housing rotation set screw.

3.7 Connect wiring and power up

WARNING

Do not remove the instrument cover in explosive atmospheres when the circuit is live.

1. Remove and discard orange shipping plugs in the conduit entries.
2. Remove the field terminals housing cover as indicated on the device.
3. Connect the positive lead to the "+" terminal, and the negative lead to the "-" terminal.
4. If grounding is required for transient protection or to fulfill local regulations, connect the ground wire as indicated in [Figure 3-3](#). The cable shield should be:
 - Trimmed close and insulated from touching the transmitter housing
 - Continuously connected to the termination point
 - Connected to a good earth ground at the power supply end

CAUTION

When the enclosed threaded plug is used in the conduit opening, it must be installed with a minimum thread engagement in order to comply with explosion-proof requirements.

For straight threads, a minimum of seven threads must be engaged. For tapered threads, a minimum of five threads must be engaged.

5. Plug and seal the unused conduit connection with the provided conduit plug. For Rosemount 4051S with conduit electrical connectors GE or GM, refer to the cordset manufacturer's installation instructions for wiring details.
6. If applicable, install wiring with a drip loop. Arrange the drip loop so the bottom is lower than the conduit connections and the transmitter housing.

7. Reinstall the housing cover and tighten so the cover is fully seated with metal to metal contact between the housing and cover in order to meet explosion-proof requirements.

NOTICE

Installation of the transient protection terminal block does not provide transient protection unless the 4051S case is properly grounded.

Figure 3-3: Wiring

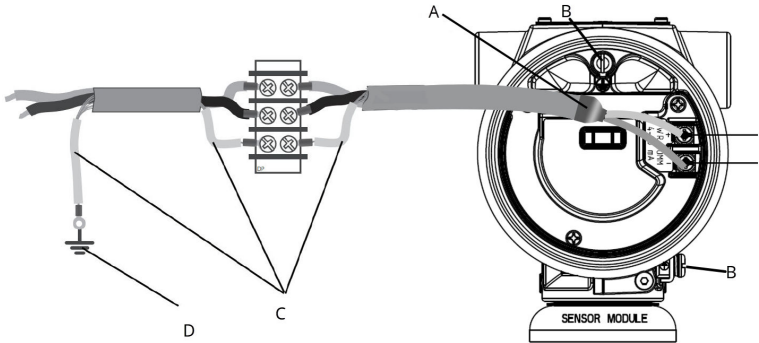

- A. Insulate shield and drain wire.**
- B. Grounding option**
- C. Insulate exposed shield drain wire.**
- D. Terminate cable shield to earth ground.**

3.7.1 Remote display wiring and power up

The remote mount display and interface system consists of a local sensor module and a remote mount LCD display assembly. The local Rosemount 4051S Transmitter assembly includes a housing integrally mounted to a sensor module. The remote mount LCD display assembly consists of a housing with a ten position terminal block.

Refer to the *Rosemount 4051S Pressure Transmitter Manual* on [Rosemount 4051S Pressure Transmitter](#) for more information, cable specifications, and requirements.

WARNING

Intrinsic safety (IS) consideration

Remote display cable parameters must be considered in an intrinsically safe installation. Refer to the appropriate hazardous locations certificate or installation drawing for safety requirements. The cable supplied with the transmitter assembly and remote display is intended for intrinsically safe installation (Emerson spare part number **04151-9900-XXXX**).

Alternative cable may be used only if parameters and installation meet the requirements outlined in the certificate or installation drawing.

NOTICE

Do not apply power to the remote communications terminal. Follow wiring instructions carefully to prevent damage to system components.

NOTICE

For ambient temperatures above 140 °F (60 °C), cable wiring must be rated at least 9 °F (5 °C) above the maximum ambient temperature.

Figure 3-4: Remote mount display wiring diagram

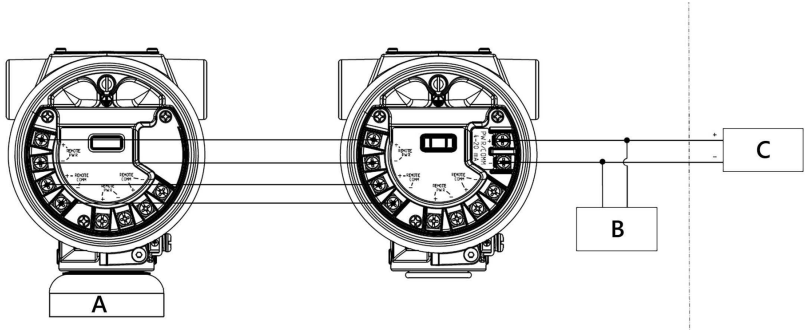

- A. Sensor module**
- B. Approved commissioning device**
- C. Approved associated apparatus**

Note

Wire color may vary depending on cable selected.

3.7.2 Power supply

The transmitter requires an external power supply providing between 11.5 to 42.4 Vdc at the terminals to operate. The total resistance load is the sum of the resistance of the signal leads and the load resistance of the controller, indicator, and related pieces.

Maximum loop resistance = $42.37 \times (\text{power supply voltage} - 11.5)$. The communication device requires a minimum loop resistance of 250 Ω for communication. Refer to the *Rosemount 4051S Pressure Transmitter Manual* on [Rosemount 4051S Pressure Transmitter](#) for more information.

NOTICE

The resistance of intrinsic safety barriers, if used, must be included.

3.7.3 Relay switches (Transmitter output code "S")

The Rosemount 4051S Pressure Transmitter supports two integral high voltage, high current single pole double throw (SPDT) switches connected directly to the transmitter. An integral relay switch takes the traditional pressure relay switch and embeds it into the transmitter.

On the 4051S, the relay switches are in the transmitter terminal block. Use the **Process Alert** function to configure the relays, which are controlled by the transmitter measurement.

Depending on how the relay is wired, this will either break or complete the circuit of a connected power load. Each of the two relays has a normally closed (**NC**) terminal, normally open (**NO**) terminal, and common (**COM**) terminal. There is a positive and negative power terminal that powers the switch separately from the positive and negative power terminal that powers the transmitter.

Refer to the *Rosemount 4051S Pressure Transmitter Manual* on [Rosemount 4051S Pressure Transmitter](#) for more information.

3.7.4 Using High-speed sensor time response (option P6)

The **High-speed sensor time response** option is available with option code **P6**. This option will change the transmitter response time to 40 ms.

The overall update rate will be dependent on **Damping** settings and if communication is via analog or HART®.

3.7.5 Set Alarm and Security switches

All Rosemount 4051S Transmitters come with **Alarm** and **Security** switches included. The transmitter will operate normally with the default **Alarm** condition High and the **Security** Off.

Refer to the related *Rosemount 4051S Pressure Transmitter Manual* <https://www.emerson.com/en/measurement-instrumentation/products/rosemount-4051s-pressure-transmitter-family> for more detail on configuration of the **Alarm** and **Security** switches.

4 Wireless configuration using Bluetooth® technology

Refer to the *Rosemount 4051S Pressure Transmitter Manual* on [Rosemount 4051S Pressure Transmitter](#) for additional installation and configuration considerations.

4.1 Download AMS Device Configurator

Download and install the AMS Device Configurator app from your preferred app store.

Note

If this is your first time opening AMS Device Configurator, you may be asked to allow the application to access media on your device and to access your device's location. If prompted, select **Allow**.

Figure 4-1: Emerson application icon



4.2 Configure using Bluetooth® wireless technology

1. Launch AMS Device Configurator.
See *AMS Device Configurator for Emerson Field Devices*.
2. Select the device you want to connect to.
3. On first connection, enter the **Unique Identifier (UID)** and **Key** for selected device and select the appropriate role.
4. At the top left, select the menu icon to navigate to the desired device menu.

4.2.1 Bluetooth® Unique Identifier (UID) and Key

You can find the **UID** and **Key** in the following locations:

- Disposable paper tag attached to the device
- Label inside the terminal block cover
- Label on the display unit

Figure 4-2: Bluetooth security information

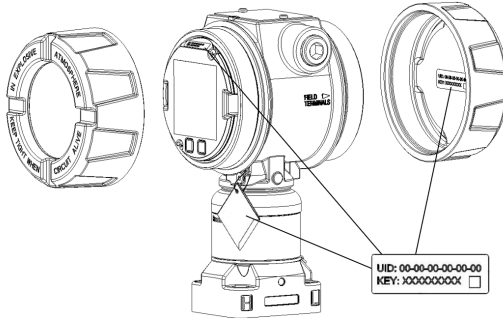

5 Verify configuration parameters

Verify configuration parameters with a HART®-compliant master before installation and install the latest device driver (DD) for optimal performance.

Use any HART-compliant master to communicate with and verify configuration of the Rosemount 4051S. Emerson recommends verifying various configuration parameters prior to installing the transmitter into the process:

- **Alarm** and **Saturation** levels
- **Damping**
- **Process variables**
- **Tag**
- **Transfer**
- **Units**

Refer to the *Rosemount 4051S Pressure Transmitter Manual* for detailed configuration details and more information.

Note

Emerson recommends installing the latest DD to ensure full functionality. Download the latest DD at [Software & Drivers](#).

6 Trim the transmitter

Emerson ships transmitters either:

- Fully calibrated per request

- By the factory default of full scale:
 - **Lower Range Value** = 0
 - **Upper Range Value** = upper range limit

Refer to the *Rosemount 4051S Pressure Transmitter Manual* on [Rosemount 4051S Pressure Transmitter](#) for greater detail on the zero trim and **Quick Service** button capabilities.

6.1 Zero trim

A zero trim is a single-point adjustment used for compensating mounting position effects.

When performing a zero trim, ensure the equalizing valve is open and all wet legs are filled to the correct level.

There are two methods to compensate for mounting effects:

- Zero trim
- Using the transmitter **Quick Service** buttons

For zero trim procedures, refer to the *Rosemount 4051S Pressure Transmitter Manual*.

7 Safety Instrumented Systems (SIS)

For safety certified installations, refer to the *Rosemount 4051S Pressure Transmitter Manual*, available on [Emerson.com](#) for installation procedure and system requirements.

8 Product certifications

8.1 European Directive information – CE

A copy of the EU Declaration of Conformity can be found at the end of the Quick Start Guide. The most recent revision of the EU Declaration of Conformity can be found at [Emerson.com/global](#).

8.2 USA — Federal Communications Commission (FCC)

This device complies with Part 15 of the FCC rules. Operation is subject to the following conditions:

- This device may not cause harmful interference; this device must accept any interference received, including interference that may cause undesired operation.
- This device must be installed to ensure a minimum antenna separation distance of 7.9 in. (20 cm) from all persons.

Changes or modification to the equipment not expressly approved by Emerson could void the user's authority to operate the equipment.

8.3 Canada — Innovation, Science, and Economic Development Canada (ISED)

This device contains license-exempt transmitter(s)/receiver(s) that comply with Innovation, Science, and Economic Development Canada's license exempt RSS(s). Operation is subject to the following two conditions:

- This device may not cause interference.
- This device must accept any interference, including interference that may cause undesired operation of the device.

Note

Changes or modification to the equipment not expressly approved by Emerson could void the user's authority to operate the equipment.

L'émetteur/récepteur exempt de licence contenu dans le présent appareil est conforme aux CNR d'Innovation, Sciences et Développement économique Canada applicables aux appareils radio exempts de licence. L'exploitation est autorisée aux deux conditions suivantes:

- L'appareil ne doit pas produire de brouillage;
 - L'appareil doit accepter tout brouillage radioélectrique subi, même si le brouillage est susceptible d'en compromettre le fonctionnement.
-

Note

Les changements ou les modifications apportés à l'équipement qui n'est pas expressément approuvé par Emerson pourraient annuler l'autorité de l'utilisateur à utiliser cet équipement.

8.4 Taiwan — National Communications Commission (NCC)

取得審驗證明之低功率射頻器材，非經核准，公司、商號或使用者均不得擅自變更頻率、加大功率或變更原設計之特性及功能。低功率射頻器材之使用不得影響飛航安全及干擾合法通信；經發現有干擾現象時，應立即停用，並改善至無干擾時方得繼續使用。前述合法通信，指依電信管理法規定作業之無線電通信。低功率射頻器材須忍受合法通信或工業、科學及醫療用電波輻射性電機設備之干擾。

8.5 Thailand — Office of National Broadcasting and Telecommunications Commission (NBTC)

เครื่องโทรคมนาคมและอุปกรณ์นี้มีความสอดคล้องตามมาตรฐานหรือข้อกำหนดทางเทคนิค ของ กสทช

8.6 Japan — Ministry of Internal Affairs and Communications (MIC)

当該機器には電波法に基づく、技術基準適合証明等を受けた特定無線設備を装着している。

8.7 Brazil — Anatel

Este equipamento não tem direito à proteção contra interferência prejudicial e não pode causar interferência em sistemas devidamente autorizados.

8.8 Mexico — Agencia de Transformación Digital y Telecomunicaciones (ATDT)

La operación de este equipo está sujeta a las siguientes dos condiciones:

1. Es posible que este equipo o dispositivo no cause interferencia perjudicial y
2. Este equipo o dispositivo debe aceptar cualquier interferencia, incluyendo la que pueda causar su operación no deseada.

8.9 Ordinary location certification

The Rosemount 4051S has been examined and tested to determine that the design meets the basic electrical, mechanical, and fire protection requirements by one or more test laboratories, accredited as follows:

- As a Nationally Recognized Test Laboratory (NRTL) by the U.S. Federal Occupational Safety and Health Administration (OSHA).
- As a part of the Certification Body Accreditation Program (CBAP) by the Standards Council of Canada (SCC).

8.9.1 Nominal operating parameters

- Permanently connected equipment

- Overvoltage category II
- Enclosure IP66/68
- Enclosure Type 4X
- Wet location

8.9.2 Environmental conditions

- Altitude: 9,842.5 ft. (3,000 m) maximum
- 0 to 100 percent relative humidity (RH)
- Ambient temperature range: -76 to +185 °F (-60 to +85 °C)
- Atmospheric temperature range: 80 kPa (0.8 bar) to 110 kPa (1.1 bar)

8.9.3 4-20 mA HART® output (A)

Electrical supply requirements: 4-20 mA HART output

Voltage (V_{MAX})	11.5 to 42.4 Vdc
Current (I_{MAX})	24 mA
Power (P_{MAX})	1.018 W

8.10 North America

8.10.1 I5 USA Intrinsic Safety (IS), Nonincendive (NI)

Certificate	FM25US0034X
Markings	IS: CL I, DIV 1, GP ABCD T4 CL II, DIV 1, GP EFG T4 CL III CL I, ZN 0, AEx ia IIC T4 Ga (-60°C ≤ Ta ≤ +70°C) NI: CL I, DIV 2, GP ABCD T4 CL II, DIV 2, GP FG T4 CL III (-60°C ≤ Ta ≤ +70°C) INSTALL PER 04151-1003 TYPE 4X IP66/IP68 OPTIONAL: DUAL SEAL - SEE PRODUCT MANUAL FOR TEMPERATURE RANGE.

Specific conditions of use:

1. The enclosure may be made from aluminum alloy with a protective polyurethane paint finish. Care should be taken to protect it from impact or abrasion when located in a Division 1 or Zone 0 area.
2. When fitted with the transient suppression electronics option (T1), the equipment is not capable of passing the 500 V insulation test. This must be considered during installation.
3. Installation of the transmitter shall be limited to Overvoltage Category II.
4. Non-standard paint options may cause risk from electrostatic discharge. Avoid installations that could cause electrostatic build-up on painted surfaces and only clean the painted surfaces with a damp cloth. If paint is ordered through a special option code, contact the manufacturer for more information.

8.10.2 E5 USA Explosionproof (XP), Dust Ignition-Proof (DIP)

Certificate	FM24US0274X
Markings	<p>EXP: Class I, Division 1, Groups B, C, D; T5 Zone 0/1 AEx db IIC T6...T4 Ga/Gb T6 (-50 °C ≤ Ta ≤ +70 °C), T5, T4 (-50 °C ≤ Ta ≤ +85 °C)</p> <p>DIP: Class II, Division 1, Groups E, F and G, Class III; T5 Zone 20 AEx ta IIIC T₂₀₀110 °C Da (not for Output code S) (-20 °C ≤ Ta ≤ +85 °C) Zone 21 AEx tb IIIC T95 °C Db (-20 °C ≤ Ta ≤ +85 °C)</p> <p>TYPE 4X IP66/IP68 SEAL NOT REQUIRED DUAL SEAL - SEE PRODUCT MANUAL FOR TEMPERATURE RANGE</p>

Specific conditions of use:

1. For AEx ta, the Rosemount 4051S must be connected to supply with a short circuit rating no more than 1.5 kA.
2. For AEx tb, the 4051S must be connected to supply with a short circuit rating no more than 10 kA.
3. Flameproof joints are not intended to be repaired.
4. The applicable temperature class, maximum surface temperature, ambient temperature range, and process temperature ranges of the equipment are as follows. Maximum ambient temperature is reduced by a ratio of 1:1.5 as process connection temperature increase beyond +85 °C.

Temperature class/maximum surface temperature	Ambient temperature range (°C)	Process connection temperature range (°C)
T6	-50 to +70	-50 to +85
T5	-50 to +85	-50 to +100
T4	-50 to +85	-50 to +121
T ₂₀₀ 110 °C	-20 to +85	-60 to +85
T95 °C	-20 to +85	-60 to +85

5. Appropriate cable, glands, and conduit seals need to be suitable for a temperature of 5 °C greater than the maximum specified ambient temperature for location where installed. Refer to temperature tables for various ambient and process temperature ranges.
6. The device contains a thin wall diaphragm less than 0.04 in. (1 mm) thick that forms a boundary between Zone 0 EPL Ga (process connection) and Zone 1 EPL Gb (all other parts of the equipment). The model code and data sheet are to be consulted for details of the diaphragm material. During installation, maintenance, and use, the environmental conditions to which the diaphragm will be subjected shall be taken into account. The manufacturer's instructions for installation and maintenance shall be followed in detail to assure safety during its expected lifetime.
7. For **Transmitter housing material "0"**, sensor module must be threaded into a 4051S housing with minimum of 7 full threads engaged and secured with set screw.

8.10.3 I6 Canada Intrinsic Safety (IS), Nonincendive (NI)

Certificate	FM25CA0016X
Markings	IS: CL I, DIV 1, GP ABCD; T4 CL II, DIV 1, GP EFG; T4 CL III Ex ia IIC T4 Ga (-60 °C ≤ Ta ≤ +70 °C) NI: CL I, DIV 2, GP ABCD; T4 CL II, DIV 2, GP FG; T4 CL III (-60 °C ≤ Ta ≤ +70 °C) INSTALL PER 04151-1003 TYPE 4X SEAL NOT REQUIRED IP66/IP68 AVERTISSEMENT - DANS UNE ATMOSPHÈRE EXPLOSIBLE GARDER BIEN FERME LORSQUE LE CIRCUIT EST SOUS TENSION OPTIONAL: DUAL SEAL - SEE PRODUCT MANUAL FOR TEMPERATURE RANGE.

Specific conditions of use:

1. The enclosure may be made from aluminum alloy with a protective polyurethane paint finish. Care should be taken to protect it from impact or abrasion when located in a Division 1 or Zone 0 area.
2. When fitted with the transient suppression electronics option (T1), the equipment is not capable of passing the 500 V insulation test. This must be considered during installation.
3. Installation of the transmitter shall be limited to Overvoltage Category II.

8.10.4 E6 Canada Explosion-Proof, Dust Ignition-Proof

Certificate	FM24CA0071X
Markings	EXP CL I, DIV 1, GP B, C, D; T5 Ex db IIC T6...T4 Ga/Gb T6 (-50 °C ≤ Ta ≤ +70 °C), T5, T4 (-50 °C ≤ Ta ≤ +85 °C) DIP CL II, DIV 1, GP E, F, G, CL III; T5 Ex ta IIIC T ₂₀₀ 110°C Da (not for Output code S) (-20 °C ≤ Ta ≤ +85 °C) Ex tb IIIC T95 °C Db (-20 °C ≤ Ta ≤ +85 °C) TYPE 4X IP66/IP68 SEAL NOT REQUIRED DUAL SEAL - SEE PRODUCT MANUAL FOR TEMPERATURE RANGE AVERTISSEMENT - DANS UNE ATMOSPHÈRE EXPLOSIBLE GARDER BIEN FERME LORSQUE LE CIRCUIT EST SOUS TENSION

Specific conditions of use:

1. For Ex ta, the Rosemount 4051S must be connected to supply with a short circuit rating no more than 1.5 kA.
2. For Ex tb, the 4051S must be connected to supply with a short circuit rating no more than 10 kA.
3. Flameproof joints are not intended to be repaired.

- The applicable temperature class, maximum surface temperature, ambient temperature range, and process temperature ranges of the equipment are as follows. Maximum ambient temperature is reduced by a ratio of 1:1.5 as process connection temperature increase beyond +85 °C.

Temperature class/maximum surface temperature	Ambient temperature range (°C)	Process connection temperature range (°C)
T6	-50 to +70	-50 to +85
T5	-50 to +85	-50 to +100
T4	-50 to +85	-50 to +121
T ₂₀₀ 110 °C	-20 to +85	-60 to +85
T ₉₅ °C	-20 to +85	-60 to +85

- Appropriate cable, glands, and conduit seals need to be suitable for a temperature of 5 °C greater than the maximum specified ambient temperature for location where installed. Refer to temperature tables for various ambient and process temperature ranges.
- The device contains a thin wall diaphragm less than 0.04 in. (1 mm) thick that forms a boundary between Zone 0 EPL Ga (process connection) and Zone 1 EPL Gb (all other parts of the equipment). The model code and data sheet are to be consulted for details of the diaphragm material. During installation, maintenance, and use the environmental conditions to which the diaphragm will be subjected shall be taken into account. The manufacturer's instructions for installation and maintenance shall be followed in detail to assure safety during its expected lifetime.
- For **Transmitter housing material "0"**, sensor module must be threaded into a 4051S housing with minimum of 7 full threads engaged and secured with set screw.

8.11 Europe

8.11.1 I1 ATEX Intrinsic Safety (Ex ia)

Certificate	FM25ATEX0006X
Markings	 II 1 G Ex ia IIC T4 Ga (-60 °C ≤ Ta ≤ +70 °C) IP66 / IP68 SEE CERTIFICATE

Specific conditions of use:

- The enclosure may be made from aluminum alloy with a protective polyurethane paint finish. Care should be taken to protect it from impact or abrasion when located in a Zone 0 area.
- When fitted with the transient suppression electronics option (T1), the equipment is not capable of passing the 500 V insulation test. This must be considered during installation.
- Installation of the transmitter shall be limited to Overvoltage Category II.
- Non-standard paint options may cause risk from electrostatic discharge. Avoid installations that could cause electrostatic build-up on painted surfaces and only clean the painted surfaces with a damp cloth. If paint is ordered through a special option code, contact the manufacturer for more information.

8.11.2 N1 ATEX Increased Safety (Zone 2/Ex ec)

Certificate	FM25ATEX0007X
Markings	Ⓜ II 3 G Ex ec IIC T4 Gc (-60 °C ≤ Ta ≤ +70 °C) IP66 / IP68

Specific conditions of use:

1. When fitted with the transient suppression electronics option (T1), the equipment is not capable of passing the 500 V insulation test. This must be considered during installation.
2. Non-standard paint options may cause risk from electrostatic discharge. Avoid installations that could cause electrostatic build-up on painted surfaces and only clean the painted surfaces with a damp cloth. If paint is ordered through a special option code, contact the manufacturer for more information.

8.11.3 E1 ATEX Flameproof, Dust Ignition-Proof

Certificate	FM24ATEX0037X
Markings	Ⓜ II 1/2 G Ex db IIC T6...T4 Ga/Gb T6 (-60 °C ≤ Ta ≤ +70 °C) T5, T4 (-60 °C ≤ Ta ≤ +80 °C) Ⓜ II 1 D Ex ta IIIC T ₂₀₀ 110 °C Da (not for Output code S) (-20 °C ≤ Ta ≤ +85 °C) Ⓜ II 2 D Ex tb IIIC T95 °C Db (-20 °C ≤ Ta ≤ +85 °C) IP66, IP68

Specific conditions of use:

1. For Ex ta, the Rosemount 4051S must be connected to supply with a short circuit rating no more than 1.5 kA.
2. For Ex tb, the 4051S must be connected to supply with a short circuit rating of no more than 10 kA.
3. Flameproof joints are not intended to be repaired.
4. The applicable temperature class, maximum surface temperature, ambient temperature range, and process temperature ranges of the equipment areas follows. Maximum ambient temperature is reduced by a ratio of 1:1.5 as process connection temperature increase beyond +85 °C.

Temperature class/maximum surface temperature	Ambient temperature range (°C)	Process connection temperature range (°C)
T6	-60 to +70	-60 to +85
T5	-60 to +80	-60 to +100
T4	-60 to +80	-60 to +121
T ₂₀₀ 110 °C	-20 to +85	-60 to +85
T95 °C	-20 to +85	-60 to +85

5. Appropriate cable, glands, and conduit seals need to be suitable for a temperature of 5 °C greater than the maximum specified ambient temperature for location where installed. Refer to temperature tables for various ambient and process temperature ranges.

6. The device contains a thin wall diaphragm less than 0.04 in. (1 mm) thick that forms a boundary between EPL Ga (process connection) and EPL Gb (all other parts of the equipment). The model code and data sheet are to be consulted for details of the diaphragm material. During installation, maintenance, and use, the environmental conditions to which the diaphragm will be subjected shall be taken into account. The manufacturer's instructions for installation and maintenance shall be followed in detail to assure safety during its expected lifetime.
7. Non-standard paint options may cause risk from electrostatic discharge. Avoid installations that could cause electrostatic build-up on painted surfaces and only clean the painted surfaces with a damp cloth. If paint is ordered through a special option code, contact the manufacturer for more information.
8. For **Transmitter housing material "0"**, sensor module must be threaded into a 4051S housing with minimum of 7 full threads engaged and secured with set screw.

8.12 International

8.12.1 I7 IECEx Intrinsic Safety (IS), Increased Safety (Zone 2/Ex ec)

Certificate	IECEx FMG 25.0008X Ex ia IIC T4 Ga (-60 °C ≤ Ta ≤ +70 °C) Ex ec IIC T4 Gc (-60 °C ≤ Ta ≤ +70 °C) IP66 / IP68
--------------------	---

Specific conditions of use:

1. The enclosure may be made from aluminum alloy with a protective polyurethane paint finish. Care should be taken to protect it from impact or abrasion when located in a Zone 0 area.
2. When fitted with the transient suppression electronics option (T1), the equipment is not capable of passing the 500 V insulation test. This must be considered during installation.
3. Installation of the transmitter shall be limited to Overvoltage Category II.
4. Non-standard paint options may cause risk from electrostatic discharge. Avoid installations that could cause electrostatic build-up on painted surfaces and only clean the painted surfaces with a damp cloth. If paint is ordered through a special option code, contact the manufacturer for more information.

8.12.2 E7 IECEx Flameproof, Dust Ignition-proof

Certificate	IECEx FMG 24.0041X
Markings	Ex db IIC T6...T4 Ga/Gb T6 (-60 °C ≤ Ta ≤ +70 °C), T5, T4 (-60 °C ≤ Ta ≤ +80 °C) Ex ta IIIC T ₂₀₀ 110 °C Da (not for Output code S) (-20 °C ≤ Ta ≤ +85 °C) Ex tb IIIC T95 °C Db (-20 °C ≤ Ta ≤ +85 °C) IP66, IP68

Specific conditions of use:

1. For Ex ta, the Rosemount 4051S must be connected to supply with a short circuit rating no more than 1.5 kA.

- For Ex tb, the 4051S must be connected to supply with a short circuit rating no more than 10 kA.
- Flameproof joints are not intended to be repaired.
- The applicable temperature class, maximum surface temperature, ambient temperature range, and process temperature ranges of the equipment are as follows. Maximum ambient temperature is reduced by a ratio of 1:1.5 as process connection temperature increase beyond 185 °F (85 °C).

Temperature class/maximum surface temperature	Ambient temperature range (°C)	Process connection temperature range (°C)
T6	-60 to +70	-60 to +85
T5	-60 to +80	-60 to +100
T4	-60 to +80	-60 to +121
T ₂₀₀ 110 °C	-20 to +85	-60 to +85
T95 °C	-20 to +85	-60 to +85

- Appropriate cable, glands, and conduit seals need to be suitable for a temperature of 5 °C greater than the maximum specified ambient temperature for location where installed. Refer to temperature tables for various ambient and process temperature ranges.
- The device contains a thin wall diaphragm less than 0.04 in. (1 mm) thick that forms a boundary between EPL Ga (process connection) and EPL Gb (all other parts of the equipment). The model code and data sheet are to be consulted for details of the diaphragm material. During installation, maintenance, and use, the environmental conditions to which the diaphragm will be subjected shall be taken into account. The manufacturer's instructions for installation and maintenance shall be followed in detail to assure safety during its expected lifetime.
- Non-standard paint options may cause risk from electrostatic discharge. Avoid installations that could cause electrostatic build-up on painted surfaces and only clean the painted surfaces with a damp cloth. If paint is ordered through a special option code, contact the manufacturer for more information.
- For **Transmitter housing material "0"**, sensor module must be threaded into a 4051S housing with minimum of 7 full threads engaged and secured with set screw.

8.13 China

8.13.1 E3 China Flameproof and Dust Ignition-proof

Certificate	GYJ25.1393X (Manufacturing USA, China)
Markings	Ex db IIC T6...T4 Ga/Gb Ex ta IIIC T ₂₀₀ 110 °C Da

Specific conditions of use:

- 产品特殊使用条件
 - 防爆合格证号后缀“X”表明产品具有特殊使用条件：
 - 产品使用环境温度范围为：

温度组别/最高表面温度	环境温度	过程温度
T6	-60 °C ≤ Ta ≤ +70 °C	-60 °C ≤ Ta ≤ +85 °C

温度组别/最高表面温度	环境温度	过程温度
T5	$-60\text{ }^{\circ}\text{C} \leq T_a \leq +80\text{ }^{\circ}\text{C}$	$-60\text{ }^{\circ}\text{C} \leq T_s \leq +100\text{ }^{\circ}\text{C}$
T4	$-60\text{ }^{\circ}\text{C} \leq T_a \leq +80\text{ }^{\circ}\text{C}$	$-60\text{ }^{\circ}\text{C} \leq T_s \leq +121\text{ }^{\circ}\text{C}$
T ₂₀₀ 110 °C	$-20\text{ }^{\circ}\text{C} \leq T_a \leq +85\text{ }^{\circ}\text{C}$	$-60\text{ }^{\circ}\text{C} \leq T_s \leq +85\text{ }^{\circ}\text{C}$

- c. 涉及隔爆接合面的维修须联系产品制造商。
 - d. 对于 Ex ta 防爆等级，产品必须连接到短路额定值不超过 1.5kA 的电源。
 - e. 电缆、引入装置、转接头密封件的适用温度需比产品的最高使用环境温度高5 °C。
 - f. 非标涂层可能导致潜在静电电荷危险，需在安装时注意，仅允许使用湿布擦拭，对于特殊涂层选项代码，需联系制造商获取更多信息。
 - g. 该设备配备厚度小于1 mm 的隔膜，该隔膜位于 0 区防爆保护等级Ga（过程链接）与 1 区防爆保护等级Gb（其他所有部件）之间，隔膜材质详情需查阅设备型号及说明书。在安装、维护和使用过程中，必须充分考虑隔膜将承受的环境条件，并严格遵守制造商的安装与维护说明，以确保设备在预期使用寿命内的安全运行。
2. 产品使用注意事项
- a. 电气参数：电压：11.5 Vdc ~ 42.4 Vdc；电流：4 ~ 24 mA (HART®)；功率：≤1W
 - b. 外壳防护等级：IP66、IP68（20 米168 小时）。
 - c. 严禁带电开盖。
 - d. 应当保持产品外表面清洁，以防粉尘堆积，但严禁用压缩空气吹扫。
 - e. 电缆引入口须配用国家指定的防爆检验机构检验认可，防爆等级为Ex db IIC Gb、Ex ta IIIC Da 的电缆引入装置或封堵件。同时，电缆引入装置或封堵件的使用必须符其使用说明书的要求。电缆引入装置或封堵件安装后，须确保设备整体外壳防护等级不低于IP66、IP68（20 米168 小时）。
 - f. 用户不得自行更换该产品的零部件，应会同产品制造商共同解决运行中出现的故障，以杜绝损坏现象的发生。
 - g. 产品的安装、使用和维护应同时遵守产品使用说明书及下列相关标准的要求：
 - h. GB/T 3836.13—2021 爆炸性环境 第13 部分：设备的修理、检修、修复和改造
 - i. GB 3836.15—2024 爆炸性环境 第15 部分：电气装置设计、选型、安装规范
 - j. GB 3836.16—2024 爆炸性环境 第16 部分：电气装置检查与维护规范
 - k. GB 15577—2018 粉尘防爆安全规程
 - l. GB 50257—2014 电气装置安装工程爆炸和火灾危险环境电气装置施工及验收规范

8.13.2 I3 China Intrinsic Safety, Increased Safety

Certificate	GYJ25.1394X [Manufacturing USA, China]
Markings	Ex ia IIC T4 Ga Ex ec IIC T4 Gc

Specific conditions of use:

1. 产品特殊使用条件
防爆合格证号后缀“X”表明产品具有特殊使用条件：
对于防爆标志Ex ia IIC T4 Ga
 - a. 产品使用环境温度范围：-60 °C~+70 °C，过程温度：-60 °C~+121 °C。
 - b. 当产品选用带有保护涂层的铝合金外壳，安装于要求EPL Ga 级的场所时，用户须采取有效措施防止产品外壳由于冲击或摩擦引起的点燃危险。

- c. 当产品选配瞬态组件T1时，不能承受500V交流有效值的介电强度试验。关联装置优先选用隔离式安全栅；如选用齐纳式安全栅，应符合GB 3836.15-2024标准关于本质安全电路接地的要求。
- d. 变送器的安装仅限于过电压类别 II。
- e. 非标涂层可能导致潜在静电电荷危险，应至少采取以下措施避免静电电荷在产品外壳上积聚：
 - i. 控制环境相对湿度以将静电产生降到最小。
 - ii. 不得干擦或吹扫产品外壳表面，以防静电引燃危险。
 对于防爆标志Ex ec IIC T4 Gc
- f. 产品使用环境温度范围：-60℃~+70℃，过程温度：-60℃~+121℃。
- g. 当产品选配瞬态组件T1时，不能承受500V交流有效值的介电强度试验。
- h. 非标涂层可能导致潜在静电电荷危险，应至少采取以下措施避免静电电荷在产品外壳上积聚：
 - i. 控制环境相对湿度以将静电产生降到最小
 - ii. 不得干擦或吹扫产品外壳表面，以防静电引燃危险。

2. 产品使用注意事项

- a. 电气参数：
 - i. 增安型额定电气参数：
 - 电压：11.5Vdc-42.4Vdc；电流：4~24mA；功率：<1.02 W
 - ii. 当防爆标志为本安型时，该产品必须与已通过防爆认证的关联装置配套共同组成本安系统方可使用于爆炸性环境，其系统接线必须同时遵守该产品和所配
 - 关联装置的使用说明书要求，接线端子不得接错。本安电气参数见下表。

端子	最高输入电压 Ui(V)	最大输入电流 Ii(mA)	最大输入功率 Pi(W)	最大内部等效参数	
				Ci(nF)	Li(mH)
电源端	30	250	1	3.3	0

- b. 增安型时，产品外壳防护等级：IP66、IP68。
- c. 安装后，产品外壳应保持等电位联结。
- d. 用户不得自行更换该产品的零部件，应会同产品制造商共同解决运行中出现的故障，以杜绝损坏现象的发生。
- e. 当防爆标志为增安型时，电缆引入口须配用国家指定的防爆检验机构检验认可，防爆等级为Ex ec IIC的电缆引入装置或封堵件。同时，电缆引入装置或封堵件的使用必须符合其使用说明书的要求。电缆引入装置或封堵件安装后，须确保设备整体外壳防护等级不低于IP66、IP68。
- f. 用户不得自行更换该产品的零部件，应会同产品制造商共同解决运行中出现的故障，以杜绝损坏现象的发生。
- g. 产品的安装、使用和维护应同时遵守产品使用说明书及下列相关标准的要求：
 - GB/T 3836.13-2021 爆炸性环境 第13部分：设备的修理、检修、修复和改造
 - GB 3836.15-2024 爆炸性环境 第15部分：电气装置设计、选型、安装规范
 - GB 3836.16-2024 爆炸性环境 第16部分：电气装置检查与维护规范
 - GB/T 3836.18-2024 爆炸性环境 第18部分：本质安全电气系统
 - GB 50257-2014 电气装置安装工程爆炸和火灾危险环境电气装置施工及验收规范

8.14 Brazil

8.14.1 E2 Brazil Flameproof and Dust Ignition-proof

Certificate	UL-BR 25.1521X (Sorocaba, Sao Pao Paulo, Brazil) UL-BR 25.1522X (Singapore) UL-BR 25.1523X (Shakopee, MN, USA)
Markings	Ex db IIC T6...T4 Ga/Gb T6 (-60 °C ≤ Ta ≤ +70 °C) T5/T4 (-60 °C ≤ Ta ≤ +80 °C) Ex ta IIIC T ₂₀₀ 110 °C Da (-20 °C ≤ Ta ≤ +85 °C)

CONDIÇÕES ESPECÍFICAS DE UTILIZAÇÃO PARA EQUIPAMENTOS Ex ou LISTA DE LIMITAÇÕES PARA COMPONENTES Ex:

Para o tipo de proteção à Prova de explosão e Proteção contra ignição de poeira por invólucro:

- Para Ex ta, o 4051S deve ser conectado a uma alimentação com capacidade de curto-circuito não superior a 1,5 kA.
- As juntas à prova de explosão não se destinam a reparo.
- A classe de temperatura aplicável, a temperatura máxima da superfície, a faixa de temperatura ambiente e a faixa de temperatura de processo do equipamento são as seguintes. A temperatura ambiente máxima é reduzida em uma razão de 1:1,5 conforme a temperatura da conexão de processo aumenta além de +85°C.

Classe de temperature/temperature máxima da superfície (°C)	Faixa de temperatura ambiente (°C)	Faixa de temperatura de processo (°C)
T6	-60 a +70	-60 a +85
T5	-60 a +80	-60 a +100
T4	-60 a +80	-60 a +121
T ₂₀₀ 110	-20 a +85	-60 a +85

- Cabos, prensa-cabos e selos de conduíte apropriados precisam ser adequados para uma temperatura 5°C superior à temperatura ambiente máxima especificada para o local de instalação. Consulte as tabelas de temperatura para as várias faixas de temperatura ambiente e de processo.
- O dispositivo contém um diafragma de parede fina com menos de 1 mm de espessura que forma uma barreira entre Zona 0 EPL Ga (conexão de processo) e Zona 1 EPL Gb (todas as outras partes do equipamento). O código de modelo e a folha de dados devem ser consultados para detalhes do material do diafragma. Durante a instalação, manutenção e uso, as condições ambientais às quais o diafragma será submetido devem ser consideradas. As instruções do fabricante para instalação e manutenção devem ser seguidas em detalhe para garantir a segurança durante a vida útil esperada.
- Opções de pintura não padrão podem causar risco de descarga eletrostática. Evite instalações que possam causar acúmulo eletrostático em superfícies pintadas e limpe as superfícies pintadas apenas com pano úmido. Se a pintura for solicitada por meio de um código de opção especial, contate o fabricante para mais informações.

Specific conditions of use for Ex equipment or schedule of Lilitations for Ex components

For explosion-proof (flameproof) and dust ignition protection types using enclosures:

- For Ex ta, the Rosemount 4051S must be connected to supply with a short circuit rating no more than 1.5 kA.
- Flameproof joints are not intended to be repaired.

- The applicable temperature class, maximum surface temperature, ambient temperature range, and process temperature range of the equipment are as follows. Maximum ambient temperature is reduced by a ratio of 1:1.5 as process connection temperature increases beyond +85 °C.

Temperature class/maximum surface temperature (°C)	Ambient temperature range (°C)	Process temperature range (°C)
T6	-60 to +70	-60 to +85
T5	-60 to +80	-60 to +100
T4	-60 to +80	-60 to +121
T ₂₀₀ 110	-20 to +85	-60 to +85

- Appropriate cable, glands, and conduit seals need to be suitable for a temperature of 5 °C greater than the maximum specified ambient temperature for location where installed. Refer to temperature tables for various ambient and process temperature ranges.
- The device contains a think wall diaphragm less than 0.04 in. (1 mm) thick that forms a boundary between Zone 0 EPL Ga (process connection) and Zone 1 EPL Gb (all other parts of the equipment). The model code and data sheet are to be consulted for details of the diaphragm material. During installation, maintenance, and use, the environmental conditions to which the diaphragm will be subjected shall be taken into account. The manufacturer's instructions for installation and maintenance shall be followed in detail to assure safety during its expected lifetime.
- Non-standard paint options may cause risk from electrostatic discharge. Avoid installations that could cause electrostatic build-up on painted surfaces and only clean the painted surfaces with a damp cloth. If paint is ordered through a special option code, contact the manufacturer for more information.

8.14.2 I2 Brazil Intrinsically Safe

Certificate UL-BR 25.1521X (Sorocaba, Sao Pao Paulo, Brazil)
 UL-BR 25.1522X (Singapore)
 UL-BR 25.1523X (Shakopee, MN, USA)

Markings Ex ia IIC T4 Ga
 -60 °C ≤ Ta ≤ +70 °C

CONDIÇÕES ESPECÍFICAS DE UTILIZAÇÃO PARA EQUIPAMENTOS Ex ou LISTA DE LIMITAÇÕES PARA COMPONENTES Ex:

Para o tipo de proteção Intrinsecamente Seguro:

- O invólucro pode ser fabricado em liga de alumínio com acabamento em tinta poliuretânica de proteção. Deve-se tomar cuidado para protegê-lo contra impacto ou abrasão quando instalado em área classificada Zona 0 / 20 (EPL Ga / Da).
- Quando equipado com a opção de eletrônica de supressão de transitórios (T1), o equipamento não é capaz de suportar o ensaio de isolamento de 500 V. Esse aspecto deve ser considerado durante a instalação.
- A instalação do transmissor deve ser limitada à Categoria de Sobretensão II.
- Opções de pintura não padronizadas podem representar risco devido à descarga eletrostática. Evite instalações que possam causar acúmulo eletrostático sobre as superfícies pintadas e realize a limpeza dessas superfícies apenas com pano úmido. Caso a pintura seja solicitada por meio de um código de opção especial, contate o fabricante para mais informações.

Specific conditions of use for Ex equipment or schedule of limitations for Ex components

For the intrinsically safe type of protection:

1. The enclosure may be made from aluminum alloy with a protective polyurethane paint finish. Care should be taken to protect it from impact or abrasion when located in a Zone 0/20 area (EPL Ga/Da).
2. When fitted with the transient suppression electronics option (T1), the equipment is not capable of passing the 500 V insulation test. This must be considered during installation.
3. Installation of the transmitter shall be limited to Overvoltage Category II.
4. Non-standard paint options may cause risk from electrostatic discharge. Avoid installations that could cause electrostatic build-up on painted surfaces and only clean the painted surfaces with a damp cloth. If paint is ordered through a special option code, contact the manufacturer for more information.

8.15 Japan

8.15.1 E4 Japan Flameproof and Dust Ignition-proof

Certificate	CML 25JPN1429X
Markings	Ex db IIC T6...T4 Ga/Gb T6 (-60 °C ≤ Ta ≤ +70 °C) T5/T4 (-60 °C ≤ Ta ≤ +80 °C) Ex ta IIIC T ₂₀₀ 110 °C Da (-20 °C ≤ Ta ≤ +85 °C)

Specific conditions of use for Ex equipment

1. For Ex ta, the Rosemount 4051S must be connected to supply with a short circuit rating no more than 1.5 kA.
2. Flameproof joints are not intended to be repaired.
3. The applicable temperature class/maximum surface temperature and ambient temperature ranges of the equipment are as follows. Maximum ambient temperature is reduced by a ratio of 1:1.5 as process connection temperature increases beyond +85 °C.

Temperature class/maximum surface temperature (°C)	Ambient temperature range (°C)	Process temperature range (°C)
T6	-60 to +70	-60 to +85
T5	-60 to +80	-60 to +100
T4	-60 to +80	-60 to +121
T ₂₀₀ 110	-20 to +85	-60 to +85

4. Appropriate cable, glands, and conduit seals need to be suitable for a temperature of 5 °C greater than the maximum specified ambient temperature for location where installed. Refer to temperature tables for various ambient and process temperature ranges.
5. The device contains a thin wall diaphragm less than 0.04 in. (1 mm) thick that forms a boundary between Zone 0 EPL Ga (process connection) and Zone 1 EPL Gb (all other parts of the equipment). The model code and data sheet are to be consulted for details of the diaphragm material. During installation, maintenance, and use, the environmental conditions to which the diaphragm will be subjected shall be taken into account. The manufacturer's instructions for installation and maintenance shall be followed in detail to assure safety during its expected lifetime.
6. Non-standard paint options may cause risk from electrostatic discharge. Avoid installations that could cause electrostatic build-up on painted surfaces and only clean the painted

surfaces with a damp cloth. If paint is ordered through a special option code, contact the manufacturer for more information.

8.16 Korea

8.16.1 EP Korean Flameproof and Dust Ignition-proof

Certificate	MANUFACTURING USA 26-KA4BO-0262X - Flameproof 26-KA4BO-0263X - Dust ignition-proof MANUFACTURING SINGAPORE 26-KA4BO-0264X - Flameproof 26-KA4BO-0265X - Dust ignition-proof
Markings	Ex db IIC T6...T4 Ga/Gb T6 (-60 °C ≤ Ta ≤ +70 °C) T5/T4 (-60 °C ≤ Ta ≤ +80 °C) Ex ta IIIC T ₂₀₀ 110 °C Da (-20 °C ≤ Ta ≤ +85 °C)

8.16.2 IP Korean Intrinsically Safe

Certificate	MANUFACTURING USA 26-KA4BO-0272X MANUFACTURING SINGAPORE 26-KA4BO-0273X
Markings	Ex ia IIC T4 Ga (-60 °C ≤ Ta ≤ +70 °C)

8.17 India

8.17.1 EW India Flameproof

Certificate	P653292
Markings	Ex db IIC T6...T4 Ga/Gb T6 (-60 °C ≤ Ta ≤ +70 °C), T5, T4 (-60 °C ≤ Ta ≤ +80 °C)

8.17.2 IW India Intrinsically Safe and Increased Safety

Certificate	P653301
Markings	Ex ia IIC T4 Ga Ex ec IIC T4 Gc (-60 °C ≤ Ta ≤ +70 °C)

8.18 Y3 ATEX/IECEx RFID tag approvals





WARNING

Additional warnings

The plastic enclosure may present a potential electrostatic ignition hazard.

RFID tag is suitable for installation in a limited set of Zone classified locations and ambient temperature ranges when compared to the transmitter.

Certificate EPS 15 ATEX 11011X

Markings  II 2G Ex ia IIC T6/T4 Gb
 II 2D Ex ia IIIC T80 °C/T130 °C Db

Certificate IECEx EPS 15.0042X

Markings Ex ia IIC T6/T4 Gb
Ex ia IIIC T80 °C/T130 °C Db

8.18.1 Specific Conditions of Use (X):

1. Maximum ambient temperature range:
 - -55 °C to +80 °C (T6 / T80 °C)
 - -55 °C to +110 °C (T4 / T130 °C)
2. The RFID tags shall never be exposed to high electromagnetic field strengths exceeding RMS values of 1 A/m or 3 V/m, e.g., in high current electrolysis plants.
3. Electrostatic charges shall be avoided. The tags shall never be used next to strong charge generating processes.

8.19 Declaration of Conformity



EU DECLARATION OF CONFORMITY



This declaration of conformity is issued under the sole responsibility of

Rosemount Inc.
6021 Innovation Blvd
Shakopee, MN 55379
USA

that the following products,

Rosemount™ 4051S Series Pressure Transmitters
Rosemount™ 4051SFx Series Flowmeter Transmitters
Rosemount™ 4051SLT Level Transmitter

comply with the provisions of the European Union Directives, including the latest amendments, valid at the time this declaration was signed.

 *June 19, 2026* | Mark Lee | Vice President, Quality | Boulder, CO, USA
(signature & date of issue) (name) (function) (place of issue)

Authorized Representative in Europe:
Emerson S.R.L., company No. J12/88/2006
Emerson 4 street, Parcul Industrial
Tetaron II, Cluj-Napoca 400638, Romania

Regulatory Compliance Shared Services Department
Email: europaeproductcompliance@emerson.com Phone: +40 374 132 035

PED Notified Body:
DNV GL Business Assurance Italia S.r.l [Notified Body Number: 0496]
Via Energy Park
14, N-20871, Bimercate (MB)
Italy

ATEX Notified Bodies for EU Type Examination Certificates:
FM Approvals Europe Limited [Notified Body Number: 2809]
Element 78,
Ground Floor Block A,
One Georges Quay Plaza,
Dublin 2 D02 E440
Ireland

ATEX Notified Body for Quality Assurance:
SGS Fimko Oy [Notified Body Number: 0598]
Takomitie 8
FI-00380 Helsinki
Finland



EU DECLARATION OF CONFORMITY



EMC Directive (2014/30/EU)

Harmonized Standards:
EN 61326-1:2013
EN 61326-2-3:2013

Other Standards:
EN 301 489-1 V2.2.3
EN 301 489-17 V3.2.4

PED Directive (2014/68/EU)

Rosemount 4051S_CA4 & 4051S_CD2, 3, 4, 5
QS Certificate of Assessment - Certificate No. 12698-2018-CE-ACCREDIA
Module H Conformity Assessment

All other Rosemount 4051S Pressure Transmitters
Sound Engineering Practice

Transmitter Attachments: Diaphragm Seal, Process Flange,
or Manifold
Sound Engineering Practice

Rosemount 4051SFx DP Flowmeter
See DSI 1000 Declaration of Conformity

RoHS Directive (2011/65/EU)

Harmonized Standards:
EN IEC 63000:2018

Low Voltage Directive (2014/35/EU)

Harmonized Standards:
EN 61010-1:2010

Other Standards:
EN 62311:2020

Radio Equipment Directive (RED) (2014/53/EU)

Harmonized Standards:
EN 18031-1:2024
EN 300 328 V2.2.2

ATEX Directive (2014/34/EU)

EU-Type Examination Certificate: FM25ATEX0006X
Equipment protection by intrinsic safety "i"
Equipment Group II, Category 1 G
Ex ia IIC T4 Ga

Harmonized Standards:
EN IEC 60079-0:2018
EN 60079-11:2012

Type Examination Certificate: FM25ATEX0007X
Equipment protection by increased safety "e"
Equipment Group II, Category 3 G
Ex ec IIC T5 Gc

Harmonized Standards:
EN IEC 60079-0:2018
EN IEC 60079-7:2015+A1:2018

EU-Type Examination Certificate: FM24ATEX0037X
Equipment protection by flameproof enclosure "d"
Equipment Group II, Category 1/2 G
Ex db IIC T6...T4 Ga/Gb

Harmonized Standards:
EN IEC 60079-0:2018
EN 60079-1:2014
EN 60079-26:2015

EU-Type Examination Certificate: FM24ATEX0037X
Equipment dust ignition protection by enclosure "t"
Equipment Group II, Category 1 D
Ex ta IIIC T₂₀₀110°C Da
Ex tb IIIC T95°C Db (For Output Type "S")

Harmonized Standards:
EN IEC 60079-0:2018
EN 60079-31:2014

8.20 Optional RFID tag Declaration of Conformity



EU Declaration of Conformity

Company: smart-TEC GmbH & Co. KG
Address: Kolpingring 3
82041 Oberhaching

Product category: Passive LF (125 kHz) RFID Tag
Passive HF (13,56 MHz) RFID Tag

Model name: smart-DOME Freestyle Ex, smart-DOME Classic Ex

The product is in compliance with the requirements of the following European harmonisation legislations:

Harmonisation legislation:	Title:
2014/53/EU:2014-04-16	Radio equipment Directive (RED)
2011/65/EU:2011-06-08	Restriction of the use of hazardous substances Directive (RoHS)
2014/34/EU:2014-02-16	Equipment and protective systems intended for use in potentially explosive 2014/34/EU atmospheres (ATEX)

The compliance with the requirements of the European harmonisation legislations was proved by the application of the following harmonised standards and technical specifications:

Essential requirements:	Reference:
Health and safety (article 3.1(a) RED)	EN 62368-1:2014+AC:2015 EN 50364:2010
Electromagnetic compatibility (article 3.1(b) RED)	EN 301 489-1 V2.2.3 EN 301 489-3 V2.1.1
Radio equipment (article 3.2 RED)	EN 300 330 V2.1.1
Equipment within certain categories or classes (article 3.3 RED)	N/A
Hazardous substances (RoHS)	EN IEC 63000:2018
ATEX	EN IEC 60079-0:2018 EN IEC 60079-11:2012

Additional information:

The object of the declaration described above is in conformity with Directive 2011/65/EU of the European Parliament and of the Council of 8 June 2011 on the restriction of the use of certain hazardous substances in electrical and electronic equipment.

According to the EU Type Examination EPS 15 ATEX 1 1011 X issued by Bureau Veritas Consumer Products Services (Notified Body 2004).

Oberhaching, 16 November 2021

Klaus Dargatzis, General Manager

smart-TEC GmbH & Co. KG

A member of the RATHGEBER® Group

Kolpingring 3 Phone: +49 (0)89 613007-80
82041 Oberhaching Info@smartTEC.com
GERMANY www.smart-tec.com

Managing directors:

Andrea Schrägle, graduate in business administration (VWA); Andreas Schrägle, graduate in industrial engineering (FH);
Klaus Dargatzis, graduate in business administration (FH) | HR: smart-TEC Verwaltungsgesellschaft mbH, headquarter
Oberhaching; AG Mchn. B 162297 | smart-TEC GmbH & Co. KG; AG Mchn. A 74704 VAT-ID.-No.: 25263077185



8.21 China RoHS table

含有 China RoHS 管控物质超过最大浓度限值的部件型号列表 4051S, 4051SLT, 4051SF
List of 4051S, 4051SLT, 4051SF Parts with China RoHS Concentration above MCVs

产品中有毒物质的名称及含有的信息表 Names and information table of hazardous substances in product						
部件名称 Part Name			电子组件 Electronics Assembly	壳体组件 Housing Assembly	传感器组件 Sensor Assembly	
有毒物质 Hazardous Substances	铅	Lead	(Pb)	X	O	X
	汞	Mercury	(Hg)	O	O	O
	镉	Cadmium	(Cd)	O	O	O
	六价铬	Hexavalent chromium	(Cr(VI))	O	O	O
	多溴联苯	Polybrominated biphenyls	(PBBs)	O	O	O
	多溴联苯醚	Polybrominated diphenyl ethers	(PBDEs)	O	O	O
	邻苯二甲酸二正丁酯	Dibutyl phthalate	(DBP)	O	O	O
	邻苯二甲酸二异丁酯	Diisobutyl phthalate	(DIBP)	O	O	O
	邻苯二甲酸丁苯酯	Butyl benzyl phthalate	(BBP)	O	O	O
邻苯二甲酸二(2-乙基)己酯	Bis(2-ethylhexyl) phthalate	(DEHP)	O	O	O	

注 1: O: 表示该有害物质在该部件所有均质材料中的含量均不超过电器电子产品有害物质限制使用国家标准要求。

X: 表示该有害物质至少在该部件的某一均质材料中的含量超出电器电子产品有害物质限制使用国家标准要求。

Note1: O: Indicate that said hazardous substance contained in all of the homogeneous materials for this part does not exceed the limit requirement of the national standard for the restriction of the use of hazardous substances in electrical and electronic products.

X: Indicate that said hazardous substance contained in at least one of the homogeneous materials used for this part is above the limit requirement of the national standard for the restriction of the use of hazardous substances in electrical and electronic products.

注 2: 以上未列出的部件, 表明其有害物质含量均不超过电器电子产品有害物质限制使用国家标准要求。

Note2: For components not listed above, indicates that their hazardous substance content does not exceed the limit requirements of the national standard for the restriction of the use of hazardous substances in electrical and electronic products.

注 3: 组装备件说明

Note3: Spare Parts Descriptions for Assemblies

部件名称 Part Name	组装备件说明 Spare Parts Descriptions for Assemblies
电子组件 Electronics Assembly	电子电路板组件 Electronic Board Assemblies 端子块组件 Terminal Block Assemblies 升级套件 Upgrade Kits LCD 或带快速服务按钮的 LCD LCD or LCD with Quick Service Buttons
壳体组件 Housing Assembly	电子外壳 Electrical Housing
传感器组件 Sensor Assembly	传感器模块 Sensor Module



For more information: [Emerson.com](https://www.emerson.com)

©2026 Emerson. All rights reserved.

Emerson Terms and Conditions of Sale are available upon request. The Emerson logo is a trademark and service mark of Emerson Electric Co. Rosemount is a mark of one of the Emerson family of business units. All other marks are the property of their respective owners.

The "Bluetooth" word mark and logos are registered trademarks owned by Bluetooth SIG, Inc. and any use of such marks by Emerson is under license.

ROSEMOUNT™

