

DeltaV™ CTO Smart Junction Box

(CE; ATEX; IECEX; Safe Area and Zone 2 Locations)

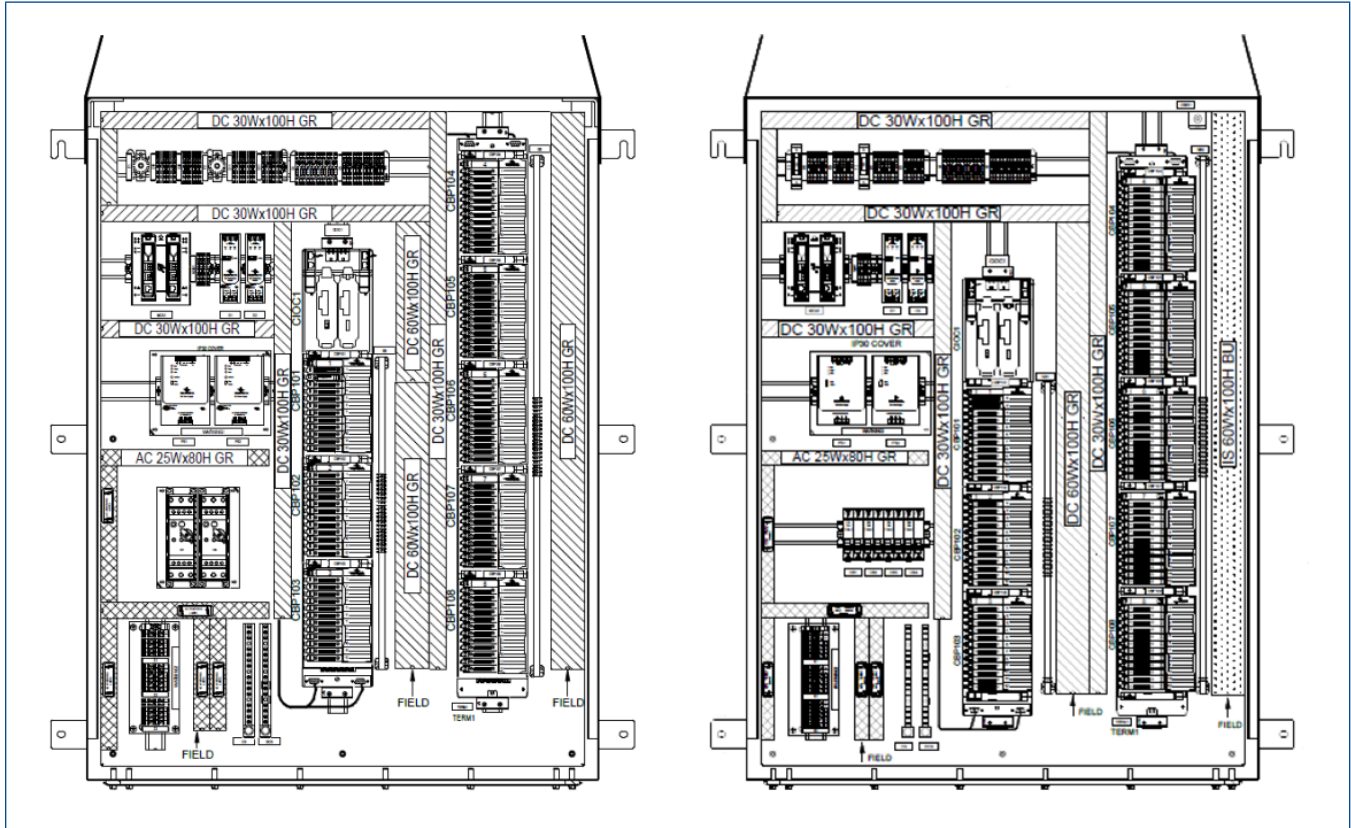

Configure to Order (CTO) CHARM Smart Junction Boxes.

- Delivers Electronic Marshalling enabled by CHARacterization Modules (CHARM) technology
- Reduce system footprint
- Eliminate I/O home run cables
- Significantly reduce SJB design engineering
- Fully documented package

Introduction

The DeltaV™ CTO CHARM Smart Junction Boxes provide an off-the-shelf solution for faster project execution and reduced installation costs. SJBs are factory tested products and ready for installation in the field. Electronic Marshalling eliminates traditional I/O design tasks and allows field wiring to start long before control strategies are finalized.

The SJBs are designed for safe area, hazardous areas and harsh environments, from extreme temperatures to corrosive gases.

Benefits

Delivers Electronic Marshalling Enabled by CHARMS

Technology: The CHARM SJBs offer the full benefits of Electronic Marshalling. The individual channels can be defined for any combination of field signal type, as required by the process equipment. This allows for 100% utilization of channels, regardless of the I/O signal mix. Late changes are easily accommodated with minimal re-engineering and no rewiring.

Reduce System Footprint: Equipment room footprint is greatly reduced by replacing traditional marshalling cabinets with field mounted I/O cards.

Eliminate I/O Home Run Cables: Field instrumentation wiring is reduced to the signal pair that connects the field device to the SJB save on home run multi-core cables, cable trays, associated engineering, and documentations.

Significantly Reduce SJB Design Engineering: The CHARM SJBs are pre-engineered, and factory tested. The I/O flexibility allows the same design to serve a wide variety of I/O signals, conditioned individually by the CHARM. Field wiring design is complete at the terminal block.

Fully Documented Package: Each SJB is supplied with full documentation and engineering drawings showing internal lay-out, bill of materials, and internal wiring.

They are designed to meet local building code and industry best practices to deliver proven functionality with minimal costs.

Product Description

The CTO CHARM SJBs offering comprises a range of pre-engineered solutions based on industry standard, wall mounting SJBs that are available in AC-powered version with space up to 96 CHARM I/O.

The designs have considered specific requirements related to outdoor installation in the field, including environmental protection, heat dissipation, power and grounding requirements, and installation in hazardous areas.

All components are prewired and tested at the factory. Simply select the required DeltaV Electronic Marshalling equipment and the enclosure is ready to install, connect the field wiring, power, and network cables. Install needed CHARMS to commission your loops and autosense the hardware into your DeltaV system.

Before delivery, each SJB undergoes a full in-house inspection and test, to assure that it is fully operational before leaving the factory. Electronic Marshalling eliminates the need for custom designs. These SJBs can be ordered, together with the DeltaV Electronic Marshalling equipment and CHARM I/O and delivered directly to site to begin field wiring (Factory Acceptance Test (FAT) with client may be optional).

The SJBs are ordered by selecting a base enclosure model and required options to meet specific project needs.

A range of base enclosure models are available:

- I/O quantities: Up to 96 I/O's.
- Distributed CHARM I/Os (combination of Max. 12 / 24 CHARMS inside SJB and external 12 CHARM I/O junction boxes – total I/O count 96).
- For ASCO Valve Solenoid outputs: 12 or 24 or 32 IOs.
- For different environmental requirements: Safe Area or Hazardous Area.
- European electrical codes/regulations.

Each base model is further explained in the coming sections.

Configurable options include the type of CHARMS (I.S. or Non-I.S.), network (Fiberoptic or Copper), enclosure Material (SS304/SS316L), cable entry, nameplate engraving, injected power, heater, etc.

System Planning

Electronic Marshalling changes the game with respect to control system I/O planning. The field I/O wiring can be designed independently from the control strategy design, allowing E&I engineers to determine the number and type of I/O based on the process design.

- Count the I/O requirements and determine the number of SJBs you need.
- Determine whether the SJB is for a safe area or hazardous area.
- Plan the power distribution and install the enclosures.
- Wire the field devices and commission them.
- When control strategies and associated controller hardware is finalized, simply assign the I/O signals to the controllers as needed, no wiring changes. You can change controller I/O assignments with the click of a mouse, without touching a wired connection.

DeltaV CTO DCS Smart Junction Box (SJB)

All CHARM SJBs come with the following equipment installed:

- AC power feeds with redundant AC/DC 24V DC bulk power supplies.
- Power distribution and isolation components for primary and secondary 24V DC Power to CHARM I/O Cards.
- Halogen-Free Cable ducts.
- Grounding bars for CG (Chassis Ground) and DC Reference Ground.
- Name Plate.
- Removable Gland Plate (3mm thick).

SJBs are designed for bottom entry for all cables (power, network, and I/O signals).

The CTO CHARM SJBs support all available low voltage CHARM I/O types with 24V DC bussed field power and all available CHARM terminal blocks.

CHARM I/O Cards (CIOC2), and CHARMs are not included and are to be ordered separately.

CTO Options

For a particular base enclosure model, several pre-engineered CTO options can be specified. These options include:

- No. of Non-IS Baseplates – Can be selected from 0 to 8
- Type of Non-IS Baseplate assembly – Can be selected with 4 different types of CHARM terminals
- No. of IS Baseplates – Can be selected from 0 to 8
- CHARMS I/O Gateway Assembly – can be selected from 2 diff. types of Networking topologies
- Non-IS and IS baseplates installation possible in single column

Enclosure Material: Stainless Steel SS304 or SS316L. Stainless steel provides protection for corrosive environments (category NEMA 4X). SS316L provides superior corrosive protection and is typically applied in offshore applications (salt resistant).

- Pre-drilled bottom entry with cable glands for I/O, power, communications, and grounding cables
- With standard drill pattern (with stop plugs) or cable transit system with flexible cable gland blocks that are installed in a cable entry frame
- Name plate engraved with custom supplied SJB identification information

24V DC Power Distribution for Injected Power or 4-wire Transmitter Power: 8 fused circuits, pre-wired to all Non-IS baseplates (This option includes a redundancy diode to bring primary and secondary power feeds to a common injected power distribution).

- **Heaters** for extreme low temperature installations & condensation management
- Blue marking for IS signals Field Cable ducts
- Breather: SS316L
- CIOC Network: Fiber Optic / Copper
- **Warning label languages** other than standard English, French, Spanish, and German

All CTO options are implemented, tested, and shipped to site as one package, significantly reducing the required upfront design and certification effort.

The following sections provide a more detailed specification for the SJBs and available options.

Overview of DeltaV CTO DCS Smart Junction Boxes (SJB) – Base Models

CTO Base Model No.	Description	No. of CHARM I/Os	Power Requirements (Pri and Sec)	Permitted Location
EU-FE-96-AC-CIOC-HA	AC Powered Smart Junction Box up to for 96 CHARM I/O; CE; ATEX/IECEX; Zone 2 Locations	Up to 96	220 to 240V AC / 100 to 120V AC	Hazardous Area ATEX/IECEX; Zone 2
EU-FE-96-AC-CIOC-SA	AC Powered Smart Junction Box up to for 96 CHARM I/O; CE; Safe Area Locations	Up to 96	220 to 240V AC	Safe Area CE
EU-FE-96-AC-VLV-SA	AC Powered Smart Junction Box up to 60 CHARM I/O and ASCO Valve Island; CE; Safe Area Locations	Up to 96	220 to 240V AC	Safe Area CE

The CTO base model reference for Smart Junction Boxes uses the following naming convention: **EU-FE-96-XX-YYYY-ZZ**, where:

EU = Europe Design Standards and Regulations

FE = Field Enclosure (Smart Junction Box)

96 = Maximum I/O's count in this CTO model

XX = Incoming Power, AC: 220 to 240V AC/100 to 120V AC

YYYY = Short description of content and purpose, CIOC or VLV

ZZ = SA: for use in Safe Area, HA: for use in Hazardous Area (ATEX/IECEX, Zone 2)

Overview of SJB Base Models and Options

LEGENDS:			SJB Base Model	EU-FE-96-AC-CIOC-HA	EU-FE-96-AC-CIOC-SA	EU-FE-96-AC-VLV-SA
<ul style="list-style-type: none"> • Default option setting o Configure to option setting (Different from Default) NA Option setting not possible for SJB Base Model						
SJB Options			SJB Options Settings			
Certification	A	1	ATEX/IECEX	•	NA	NA
Ambient Temperature	B	1	-10°C to +40°C	NA		•
		2	-20°C to +50°C	•	NA	NA
		3	-40°C to +50°C	o	•	
		4	-20°C to +55°C	o	o	
Enclosure Material	C	1	Stainless Steel SS304	•	•	•
		2	Stainless Steel SS316L	o	o	o
Cable Entry	D	1	Undrilled Gland Plate	•	o	•
		2	Pre-drilled gland plate with installed cable glands	o	•	NA
		3	Pre-filled Roxtec Frame	o	o	o
Input Voltage	E	1	220 to 240V AC	•	•	•
		2	100 to 120V AC	o	NA	NA
Incoming Power Landing	F	1	Feedthrough Terminals	•	•	•
		2	Disconnect Switches	o	NA	NA
MCB Make	G	1	Eaton¹	•	NA	NA
		2	Appleton	o	NA	NA
Heaters	H	1	No	•	•	NA
		2	Single Heater (for condensation)	o	o	
		3	Two Heaters ⁷	o	NA	
AC Surge Protection Device	I	1	No	•	•	•
		2	Yes	o	o	o
24VDC Injected Power (Applicable only for Non-IS baseplates)	J	1	8 Circuits	•	•	•
		2	No	o	o	o
Enclosure Light	K	1	No	•	•	•
		2	Yes ²	o	o	o
Enclosure Fan	L	1	No	•	•	NA
		2	Yes ⁸	o	o	

LEGENDS:			SJB Base Model			EU-FE-96-AC-CIOC-HA	EU-FE-96-AC-CIOC-SA	EU-FE-96-AC-VLV-SA
<ul style="list-style-type: none"> • Default option setting o Configure to option setting (Different from Default) NA Option setting not possible for SJB Base Model								
SJB Options			SJB Options Settings					
External 12 CHARM I/O Junction BOX 24VDC Supply	M	1	No	•	•	NA		
		2	Yes	o	o			
CIOC Network	N	1	Single-mode Fiber Optic w/ Splice Cassettes	•	•	NA		
		2	Multimode Fiber Optic w/ Splice Cassettes	o	o			
		3	Single-mode Fiber Optic w/ Adapter	o	o			
		4	Multimode Fiber Optic w/ Adapter	o	o			
		5	Copper	o	o	•		
		6	Fiber Optic IOP	NA	NA	o		
Door Opening Alarm	O	1	No³	•	•	•		
		2	Yes	o	NA	NA		
Type of Valve	P	1	12 Coil configuration Valve Island	NA	NA	•		
		2	24 Coil configuration Valve Island	NA	NA	o		
		3	32 Coil configuration Valve Island	NA	NA	o		
CHARMS I/O Gateway Assembly	Q	1	No	•	•	NA		
		2	Yes	o	o			
Type of CHARMS I/O Gateway Assembly	R	1	No	•	•	NA		
		2	Redundant CHARM I/O Gateway Assembly for Ring Topology	o	o			
		3	Simplex CHARM I/O Gateway Assembly for Ring Topology	o	o			
		4	Redundant CHARM I/O Gateway Assembly for Star Topology	o	o			
		5	Simplex CHARM I/O Gateway Assembly for Star Topology	o	o			
I/O Type Selection⁴	S	1	Up to 96 I/O - Non-IS, IS or Mix	•	•	NA		
		2	60 I/O - Non-IS	NA	NA	•		
		3	60 I/O - IS			o		

LEGENDS:		SJB Base Model				
<ul style="list-style-type: none"> • Default option setting o Configure to option setting (Different from Default) 		EU-FE-96-AC-CIOC-HA	EU-FE-96-AC-CIOC-SA	EU-FE-96-AC-VLV-SA		
NA Option setting not possible for SJB Base Model						
SJB Options		SJB Options Settings				
Type of Non-IS Baseplates Assembly	T	1	With Standard CHARM Terminal Blocks	•	•	NA
		2	With 3-wire DI Fused Injected Power CHARM Terminal Blocks	o	o	
		3	With Fused Injected Power CHARM Terminal blocks	o	o	
		4	With Relay Output CHARM Terminal Blocks	o	o	
Warning Labels Languages	U	1	STANDARD LABEL (ENG+FRN+GER+SPN)	•	•	•
		2	ENG+FRN+GER+USER SPECIFIC LANGUAGE	o	NA	NA
		3	ENG+FRN+SPN+USER SPECIFIC LANGUAGE	o	NA	NA

1. Eaton MCB is rated for -20°C at lower side, hence it is disabled for selection for ambient temperature range of -40°C To +50°C.
2. For ATEX/IECEX certified SJB, when the "Enclosure Light" option is selected, the door switch will be added in the design. The light will be operated through the door switch.
3. Door Opening Alarm will be available by default for ATEX / IECEX certified SJB, when "Enclosure Light" option is selected.
4. Selection of required CHARM Baseplate (CBP) quantity and type is possible. The Max. CBP quantity is dependent on:
 - Temperature selection
 - 24VDC for injected power or 4-wire transmitters
 - External 12 CHARM I/O Junction BOX 24VDC Supply (Consumes space for 2 CBP)
 - CHARMS I/O Gateway Assembly (Consumes space for 1 CBP)
5. Min. 1 CBP (IS / Non-IS) selection is mandatory for connecting SJB's diagnostic alarms to the CHARMS CBP.
6. In case of all Non-IS CBP or IS/Non-IS mix CBP selection, Non-IS type CHARMS will be selected for SJB's diagnostic alarm connection. When all IS CBPs are selected, IS CHARMS will be selected for alarm connection. Total installable CHARMS qty. in SJB will be reduced by 2 as 2 CHARMS are required for diagnostic alarm connection of that SJB.
7. Two heater option is applicable for ambient temperature range -20°C to 50°C and -40°C to 50°C only.
8. Enclosure fan option is default "Yes" for ambient selection of "-20°C to +55°C".

General Specifications for CTO CHARM SJBs

General Specifications for CTO CHARM SJBs	
Material (*)	Stainless Steel SS304/SS316L, Enclosure Thickness 2mm Mounting plate Thickness 2.5mm
Dimensions	915mm (W) x 1220mm (H) x 475mm (D) (without lifting pads and mounting brackets)
Access	Single door (Thickness 2mm), left hand hinged
Protection Category	IP 66** -Type 4X (Corrosive Environment)
Cable Entry (*)	Bottom, single gland plate (Thickness 3mm)
Name Plate	Outside Door: Laser engraved plastic
Weight	~165 kg (may vary as per hardware added by option selection)
Control Network (*)	Options available for Control Network: 1. Redundant Single Mode FO with Media Converter (Adapter / Splice Cassettes) 2. Redundant Multi-Mode FO with Media Converter (Adapter / Splice Cassettes) 3. Redundant Copper (RJ45) Fiber Optic Control Network Includes: <ul style="list-style-type: none"> ■ FO to Copper Media Converter (MM or SM as per type of FO selected). Media converter has one 100 BASE-FX (SM/MM) port with LC Connector. ■ SC-LC FO patch cables, Multimode 50/125-micron core/ cladding diameters (OM2) or Single mode 9/125-micron cable.
Power Requirements – Internal Power Distribution	Primary and secondary AC power supply supplied from outside the Smart Junction Box. Redundant AC power distribution through power terminals, and circuit breakers. 24 VDC bulk power supplies full redundant (Primary and Secondary): <ul style="list-style-type: none"> ■ 2 x 20A for 50°C ambient selection ■ 2 x 10A for 50/55°C ambient selection
Diagnostic Alarm	<ul style="list-style-type: none"> ■ Bulk Power supplies failure alarm and door open alarm (if selected), connected in series ■ High temperature alarm
Provision of Power distribution for external 12 CHARM I/O Junction boxes	Input power required by external 12 CHARM I/O Junction boxes (24VDC +/- 10%) is supplied from Smart Junction Box. This can be: <ul style="list-style-type: none"> ■ Redundant (Redundant pair of power cable from SJB to individual external 12 CHARM I/O BOX junction Box). ■ Maximum power cable distance from Smart Junction Box to 12 CHARM I/O Junction box is 100mtr. Maximum power cable termination possible in 12 CHARM I/O Junction box is 2.5mm² (14AWG). ■ User should daisy chain Pri. and Sec. input power terminals of 12 CHARM I/O Junction box to avoid alarm for non-redundancy power in case of Simplex power is considered.

General Specifications for CTO CHARM SJBs	
CHARM Baseplate Flexibility (Except for Valve SJB)	<ul style="list-style-type: none"> ■ The selection is available for Non-IS CHARM Baseplates with 4 different types of CHARM Terminals blocks. ■ Even in case of 55°C ambient temperature Injected power to the CHARM Baseplate option is available with the restriction on no. of Non-IS CHARM baseplates. ■ Mix of Non-IS and IS CHARM Baseplates in 1 column is possible.
CHARMS I/O Gateway Assembly	The selection is available for CHARM I/O Gateway Assembly with 2 different types of networking topologies (Star / Ring) in Simplex / Redundant configuration of each type.
Supply Includes	Mounting plate, Halogen-Free wire ducts, external wall mounting brackets, door clamps, ground bars, external grounding bolt, drip edge, breather-drain.

(*) For available configurable options refer to respective base SJB model & option table.

(**) IP64 – with wing knob for padlock.

Additional General Specifications for 96 I/O CHARM Valve SJB

General Specifications for 96 I/O CHARM Valve SJB	
ASCO Valve Details	<p>ASCO Valve will be connected to CIOC bus through top or bottom extenders using extender cables. ASCO Valve model to be selected as per project requirement.</p> <p>No. of channels of Valve unit will be considered in 96 I/O count of CIOC bus.</p> <p>IP 65* –Type 4X (Corrosive Environment)</p>

(*) IP64 – with wing knob for padlock.

SJB General Arrangements

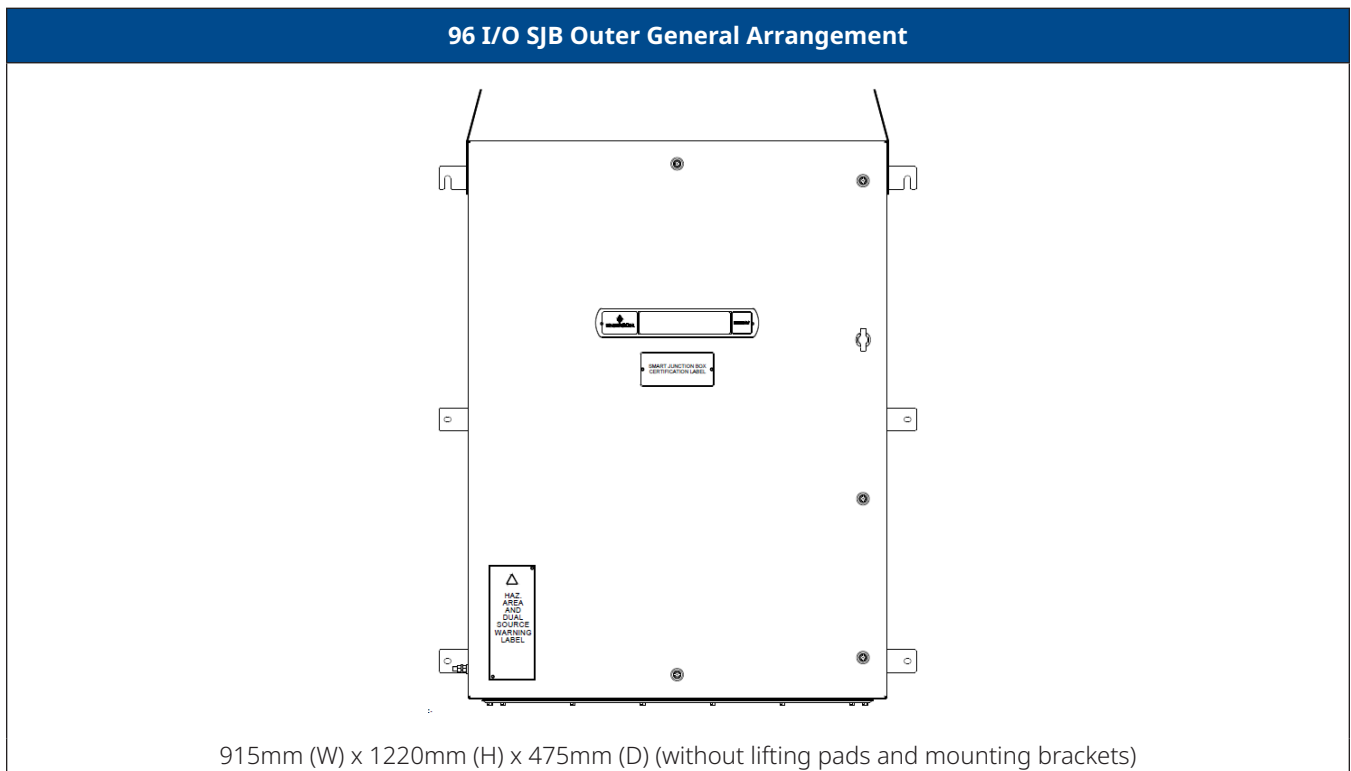

Internal General Arrangement of SJBs

96 I/O SJB Internal General Arrangements

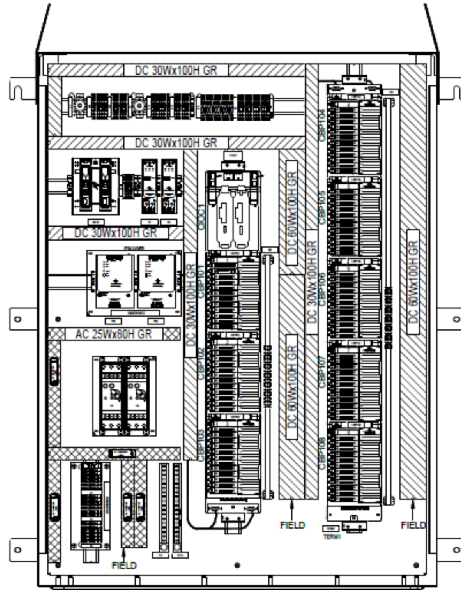
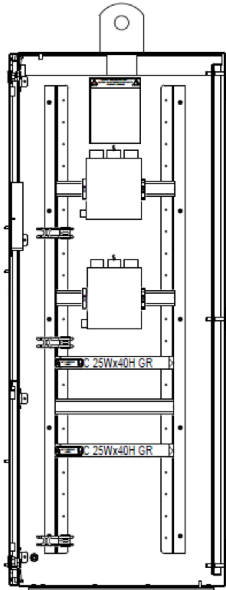

EU-FE-96-AC-CIOC-HA OR EU-FE-96-AC-CIOC-SA

These SJBs has space for:

- 1 x CIOC Carrier with redundant Copper Ethernet connectors
- Max. 8 No. of Non-IS and IS CHARM Base Plate as per user selection
- 1 X CHARMS I/O Gateway Assembly
- 24VDC Redundant Power distribution for up to 7 External 12 CHARM I/O Junction boxes

96 I/O CHARM Valve SJB Internal General Arrangements

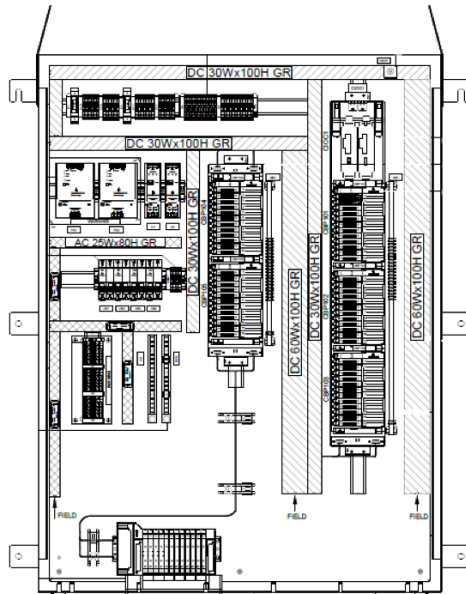
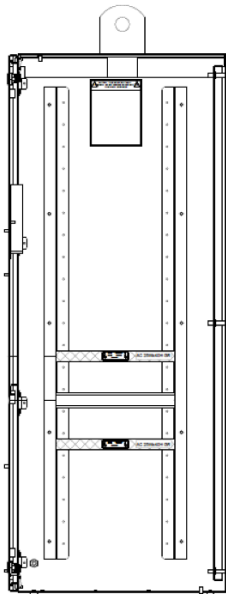

EU-FE-96-AC-VLV-SA

These SJBs has space for:

- 1 x CIOC Carrier with redundant Copper Ethernet connectors
- Max. 5 No. of Non-IS OR IS CHARM Base Plate as per user selection
- ASCO Valve model as per selected type

Design Considerations

Power and Heat

The rated ambient temperature for each SJB model is listed in the table of Overview of SJB Base models and options. The maximum internal operating temperature for each SJB model is listed in the table below.

CTO SJB Model	Maximum Internal Operating Temperature
EU-FE-96-AC-CSLS-HA EU-FE-96-AC-CSLS-SA	60°C*
EU-FE-96-AC-VLV-SA	50°C**

*Bulk Power supply will derate after 60°C.

**ASCO valves are rated for max. 50°C operating temperature.

Caution: Operating any electronics at the higher end of its temperature range for long periods of time will shorten its expected lifetime, see **Effects of Heat and Airflow Inside an Enclosure White Paper** for more information.

The CTO SJBs are configurable. The type of hardware configured and IO quantity which can be accommodated depends on ambient temperature and acceptable internal temperature rise within SJB.

For each SJB, a heat and power calculation must be done to assess whether internal temperature rise is acceptable for the IO quantity considered and configured options considered. Appropriate safety margin may be kept. A CTO Heat and Power calculation Template is available to assist this.

SJB Location

Direct sunlight significantly impacts heat rise within the SJB. It is must to install the SJBs in a permanent shade to prevent them from being exposed to direct sunlight.

Humidity

SJBs are suitable for installation in environment with 5-95% relative humidity, Non-condensing.

System Compatibility

The CTO SJB comes with CIOC carrier with New Copper IOP which is supported in v13.3.1 or later software.

CHARM I/O hardware requires:

- S-Series controllers with DeltaV v11.3.1 or later software.
- M-Series and PK controllers with DeltaV v14.3 or later software.

Certifications

The CTO CHARM SJBs are designed with components that meet or exceed the following certifications. Depending on the enclosure type (see specs):

- **CE**
 - EN 61326-1, EN 61010-1
- **ATEX: Sira 16ATEX4047X**
 - EN IEC 60079-0, EN 60079-1, EN IEC 60079-7, EN 60079-11, EN IEC 60079-15, EN 60079-28
- **ATEX/IECEx Marking**
 - Ex II 3(3) G/ Ex db ec ic [ic] nC op is IIC T4 Gc with NON-IS CHARMS
 - Ex II 3(1) G/ Ex db ec [ia Ga] ic nC op is IIC T4 Gc with IS CHARMS
- **IECEx: SIR 16.0019X**
 - IEC 60079-0, IEC 60079-1, IEC 60079-7, IEC 60079-11, IEC 60079-15, IEC 60079-28

Refer to the **DeltaV Electronic Marshalling** or to the **DeltaV IS Electronic Marshalling** Product Data Sheet for certification information on the DeltaV DCS CHARM system components.

Ordering Process

CTO CHARM SJBs are available for ordering via Emerson iCenters.

Basically, the following steps are followed to obtain a CHARM Smart Junction Box:

1. Specify the CHARM SJB by selecting the base model and the options required for the project.
 - A Configuration tool is available to aid in the selection of the right combination of options for your CTO SJB.
2. Generate the specification sheet from the Cabinet configuration tool (CCT) and send this to your regional iCenter.
3. Based on the specification, you will then receive:
 - A quotation for the fully assembled SJB.
 - The detailed specification (drawing package) matching your configuration, including the Bill of Materials.
4. Approve the drawing package for construction.
5. Order the CTO CHARM SJB as per provided quotation and approved drawings.
6. The CHARM SJB is assembled, factory tested and delivered to site. The delivery includes the as-built drawing package (AutoCAD).

For questions related to specific project quotations or order processing, please contact your local Emerson Sales office or your regional Emerson iCenter:

For Europe (iCenter Cluj):

Cabinets.Quotes@Emerson.com

For Middle East, Africa, and Asia Pacific (iCenter Nashik):

rfqicenter.nsk@emerson.com

Project Customizations

“...What if a CTO Smart Junction Box is 90% what I need, but I really need my SJB to have...”

For any customizations as a variation or addition to the standard CTO offering can often be developed in such a way that the additional effort is incremental.

In case your project would require a customer witnessed FAT, this can also be accommodated.

Please work with your local Emerson Sales office or regional Emerson iCenter to evaluate any impacts of requested customizations to cost, delivery time and certifications.

Related Products

- CHARM I/O Cards (CIOC2) must be ordered separately.
- Individual I/O CHARM modules must be ordered separately as per project requirement. The cost of installation and testing of CHARM modules is not included.

©2025, Emerson. All rights reserved.

The Emerson logo is a trademark and service mark of Emerson Electric Co. The DeltaV logo is a mark of one of the Emerson family of companies. All other marks are the property of their respective owners.

The contents of this publication are presented for informational purposes only, and while diligent efforts were made to ensure their accuracy, they are not to be construed as warranties or guarantees, express or implied, regarding the products or services described herein or their use or applicability. All sales are governed by our terms and conditions, which are available on request. We reserve the right to modify or improve the designs or specifications of our products at any time without notice.

Contact Us

www.emerson.com/contactus