

DeltaV™ M-series Virtual I/O Module 2

- Non-intrusive DeltaV™ I/O simulation
- Powerful integration solution
- Easy to use
- Modular, flexible packaging



The M-series Virtual I/O Module 2 provides DeltaV™ I/O simulation and a high speed Ethernet I/O device integration platform.

Introduction

The DeltaV™ M-series Virtual I/O Module 2 (VIM2) provides non-intrusive simulation of the DeltaV M-series I/O Cards and digital bus field devices for process simulation when used with DeltaV Mimic software. DeltaV control strategies and system configurations can be fully evaluated with this powerful simulation interface.

The VIM2 also provides an interface to Ethernet I/O networks and devices that use e.g., the Modbus TCP or EtherNet/IP protocol drivers. DeltaV M-series controllers can read and write signals from plant floor devices connected to Ethernet I/O networks such as PLC's, motor control centers, and weigh scales.

Benefits

Non-Intrusive DeltaV I/O Simulation

Use the VIM2 in conjunction with DeltaV Mimic to simulate your DeltaV M-series I/O and digital bus field devices.

- **Supports DeltaV I/O Modules** – Provides completely non-intrusive simulation of all DeltaV M-series I/O Modules. DeltaV configuration can be fully evaluated without modifying the control strategies.
- **Digital Bus Support** – Provides simulation of all DeltaV digital busses and FOUNDATION Fieldbus function blocks. Supports FOUNDATION Fieldbus control simulation for the field configuration testing.
- **Powerful Simulation Solution** – Provides full simulation of up to 64 DeltaV I/O modules per controller. Simulation execution is fast and efficient; the DeltaV controller thinks it is talking with real IO.

Powerful Integration Solution

Use the VIM2 in conjunction with the **Ethernet I/O** drivers to integrate your DeltaV system with your Ethernet I/O device networks.

- **Large Device Capacity** – Connect to dozens of independent field devices through a single VIM2. Communication over the Ethernet I/O device network is fast and efficient.
- **Flexible Networking** – User configurable IP addressing allows VIM2 use in almost any plant environment regardless of networking scheme. For some protocols, the VIM2 and the Ethernet I/O devices must be on the same IP subnet to communicate.
- **1:1 Redundancy** – Redundancy is achieved by adding a second VIM2 and configuring the two cards as a redundant pair - when supported by the protocol. The VIM2 appears as four redundant card pairs. Automatic switchover of primary to standby cards is driven by the VIM according to protocol-specific rules and appears in DeltaV as a standard I/O card switchover for the full set of cards. The operator is given clear notification of a switchover at the operator display. Manual switchover can be initiated from DeltaV as well.

Easy to Use

The VIM2 is easy to use and well integrated into the DeltaV system. Specific ease of use features include:

- **Simple Updates** – Simulation I/O driver updates for the VIM2 are included with Mimic software releases. Updates are quick and easy over the simulation network.
- **Seamless Ethernet I/O Integration** – When used with the Ethernet I/O drivers, the VIM2 appears to DeltaV controllers as four DeltaV IO Cards.
- **Intuitive Setup** – The VIMNet Explorer application provides plug-n-play capability making setup of the VIM2 easy and intuitive. Graphical, drag-n-drop, functionality makes setting up multiple VIM2s almost effortless. VIMNet Explorer is integrated with DeltaV Explorer to make setup of the VIM2 easy and intuitive.

Modular, Flexible Packaging

The VIM2 mounts in the same manner as the DeltaV controller. It mounts in the controller slot of a DeltaV 2-wide horizontal or 4-wide vertical carrier and uses a standard DeltaV System Power Supply. The VIM2's carrier(s) are installed to the immediate right or left of the controller carrier(s). The advanced design of the VIM2 will provide years of uninterrupted use.



M-series system power supply and VIM2.

Product Description

The VIM2 may be used for either DeltaV I/O simulation or Ethernet I/O device integration. The VIM2 mounts on a 2-wide horizontal or 4-wide vertical carrier on either side of the DeltaV controller. A dedicated DeltaV system power supply is required.

IO Simulation

- When used with DeltaV Mimic software, the VIM2 supports I/O simulation all DeltaV M-series I/O cards including classic IO, FOUNDATION Fieldbus, Profibus DP, DeviceNet, ASi-bus and Serial.

Mimic provides dynamic simulation for DeltaV system software acceptance testing and operator training. Mimic works by simulating the DeltaV I/O. It also simulates field devices using FOUNDATION Fieldbus, Profibus DP, DeviceNet, and AS-i buses. For Mimic to do this, the physical I/O cards are disconnected from the control system. The Mimic driver writes to the I/O subsystem of the DeltaV controller. Process models in Mimic simulate realistic process reactions to control system output signals.

Each offline process controller uses one Mimic simulation node and VIM. The I/O simulation driver is available with Mimic.

Ethernet I/O Integration

When used with the Ethernet I/O drivers, the VIM2 can communicate with high-speed Ethernet networks over Modbus TCP or EtherNet/IP. Depending on redundancy configuration of the VIM2, the DeltaV controller auto-senses a commissioned VIM2 as four or eight DeltaV I/O Cards.

- In simplex installations these cards will be sensed in slots 57-60 or 61-64.
- In dual simplex installations these cards will be sensed in slots 57 to 64.
- In redundant installations the redundant pairs will be sensed in slots 57 to 64.

Users configure the I/O signals for commissioned VIM2s in DeltaV Explorer in the same manner as a DeltaV Serial, or DeviceNet.

VIMNet Explorer

VIMNet Explorer allows the user to commission the VIM2; setup primary, secondary, and/or redundant VIM2s; define the Ethernet I/O network; and view advanced diagnostics information. The user can specify the IP address, Subnet Mask, and Gateway of each VIM2 and set the node address and names of each Ethernet I/O device integrated with the VIM2. VIMNet Explorer is also used to flash upgrade a VIM2 from one version of a driver to another or to replace an existing driver type with another. Only one Ethernet I/O driver may be loaded in the VIM2 at one time.

VIMNet Explorer application must run on a workstation that has network connectivity to the Ethernet I/O network. This may be a DeltaV workstation with the third network interface card (NIC) connected to the Ethernet I/O network or may be a non-DeltaV workstation. Connection to the VIM2 is done through the RJ-45 Network Connection on the bottom of the VIM2.

VIMNet Explorer installation media is downloadable from Guardian.

VIM2 Dual Simplex or Redundant Setups

Two VIM2s can either be setup as a dual simplex or redundant pair for installations that either consists of many field devices or require additional communication resiliency, respectively.

If two VIMs are configured for dual simplex operation, both VIM2s will work as Standalone units and no redundancy link cable is installed.

If two VIMs are configured for redundant operation, the active and standby VIM2s monitor each other with a continuous status command using the redundancy link cable supplied with each redundant pair. The active VIM2 communicates over the network to the Industrial Ethernet device and the standby sends an intermittent signal to the device to maintain communication integrity.

The Ethernet I/O drivers are available separately from the VIM2 hardware. Each operating VIM requires one license for the running protocol. For example, a redundant pair of VIMs requires two copies of the driver running on that pair, but an offline spare does not require licensing.

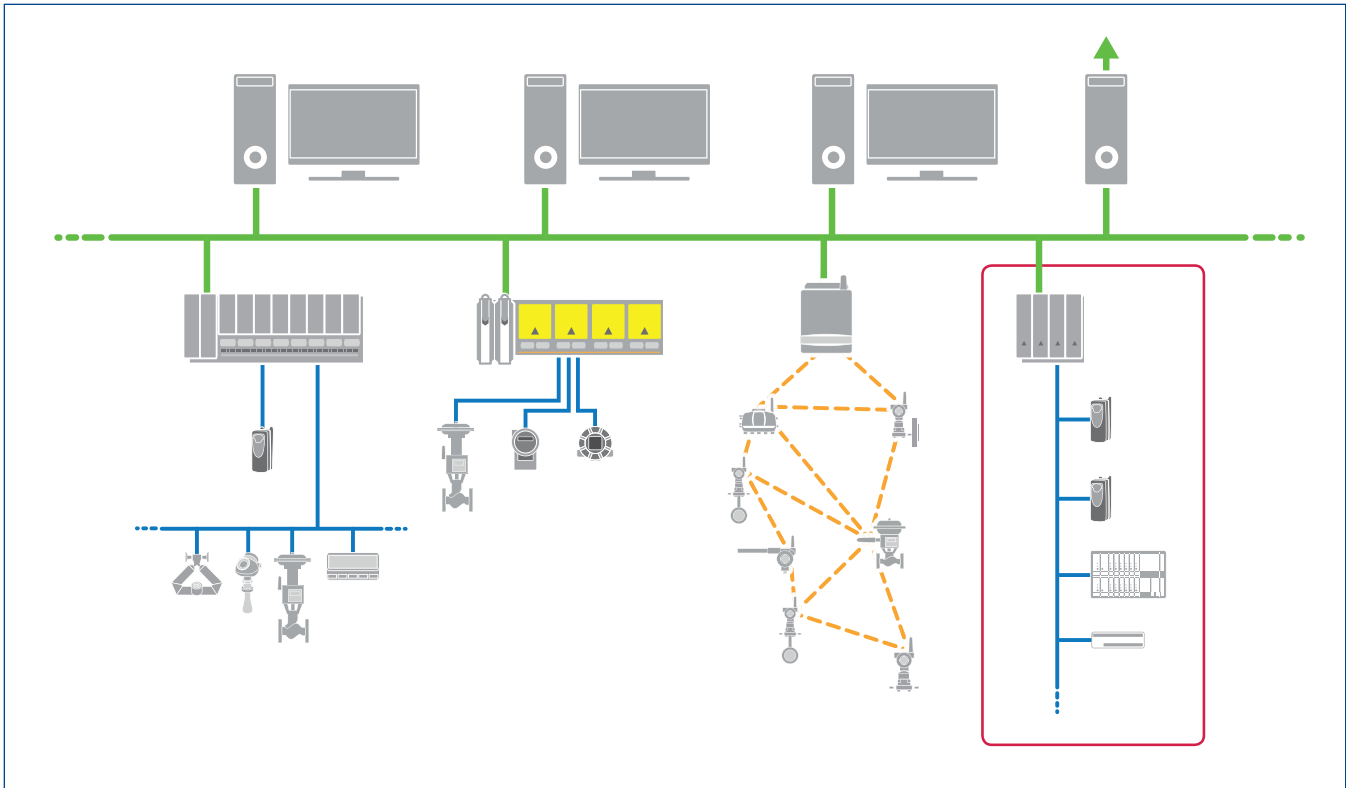

The DeltaV system with M-series VIM2 and Ethernet I/O integration (simplex VIM2 and DeltaV controller shown).

Supported Industrial Ethernet Protocols

Modbus TCP

The VIM2 with the Modbus TCP Driver supports the following Modbus communications protocol function codes to read and write values to and from Modbus devices, as specified by the Modbus Application Protocol Specification from Modbus-IDA.org. This driver emulates Programmable Serial cards on the DeltaV I/O Bus.

The VIM2 Modbus TCP/IP Driver supports the following Modbus function codes:

- Code 1 - Read Coil Status
- Code 2 - Read Input Status
- Code 3 - Read Holding Registers
- Code 4 - Read Input Registers
- Code 5 - Force Single Coil
- Code 6 - Preset Single Register
- Code 8 - Diagnostic Loop Back Test

- Code 15 - Force Multiple Coils
- Code 16 - Preset Multiple Registers

The VIM2 can function as both a Modbus TCP master and slave simultaneously. Master or slave mode is set at the virtual port level. The master and slave capability are available in simplex implementations; in redundant applications, only master mode is supported.

Rockwell PLC Scanner

The VIM2 with the Rockwell PLC Scanner Driver provides the following compatible functions using the Common Industrial Protocol (CIP) as defined in the EtherNet/IP Specification from Open DeviceNet Vendor Association and ControlNet International. This driver emulates Programmable Serial cards on the DeltaV I/O bus.

The VIM2 EtherNet/IP Scanner Driver provides:

- IO Adapter (Transport Class 1 target, using connected implicit messaging). Supported in simplex or dual simplex configurations.
- Unconnected explicit (UCMM) messaging client Embedded DF1 (PCCC). Supported in simplex, dual simplex, and redundant configurations.

EtherNet/IP

The VIM2 with the EtherNet/IP Driver provides the following compatible functions using the Common Industrial Protocol (CIP) as defined in the EtherNet/IP Specification from Open DeviceNet Vendor Association (ODVA) and ControlNet International. The driver emulates either Programmable Serial cards or DeviceNet cards on the DeltaV I/O bus.

The VIM2 EtherNet/IP Scanner Driver provides:

- I/O Scanner (Transport Class 1 originator, using connected implicit messaging).
- I/O Adapter (Transport Class 1 target, using connected implicit messaging).
- Unconnected explicit (UCMM) messaging client.
- Connected explicit (Transport Class 3 originator) messaging client.

Additional Integration Options

Please review the **PK Controller**, **PK Flex Controller**, and **Ethernet I/O Card (EIOC)** product data sheets for additional Industrial Ethernet protocol integration options.

DeltaV™ Licensing Guidelines

DeltaV I/O licensing for the VIM2 depends on the I/O cards the VIM is emulating and follows that card type’s rules.

Programmable Serial Interface Cards

Serial dataset registers can be referenced directly in control modules as analog or discrete I/O providing fast easy data exchange with the serial device. Direct module-to-Dataset/register references are recommended for control signals.

Alternatively, users can read multiple registers from a Dataset into a single “marshalling” module at the cost of a single DST. Marshalling modules provide a cost-effective way to integrate serial data from analyzers and other data sources. Serial dataset registers can also be passed as SCADA values directly to Workstations and Continuous Historians without consuming DST’s.

See the M-series Serial Interface Series 2 product data sheet for additional details.

DeviceNet Interface Cards

In DeltaV v12 and later, the number of DSTs per connected DeviceNet device will be 1 DST in most cases. The DST type counted will be the most valuable type used to reference

a signal for each device. If references are made to more than 16 signals from a device, additional signal references beyond the 16th reference will each count as a DST. A motor starter, for example, with 4 to 5 signal references, will consume 1 DST (typical an AI or DO DST). A remote I/O island will consume 1 DST for the first 16 signal references, and 1 DST for each additional signal reference beyond the 16th signal reference.

See the **M-series DeviceNet Interface Card** product data sheet for additional details.

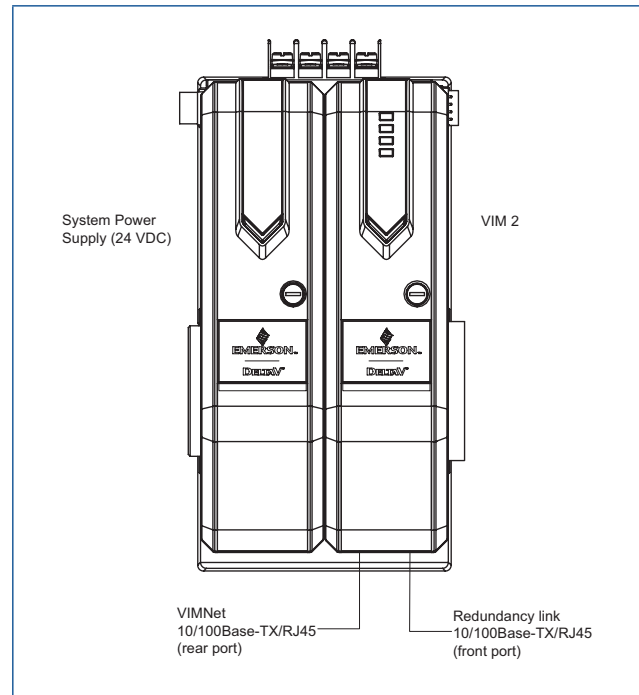

M-series system power supply and VIM2 details.

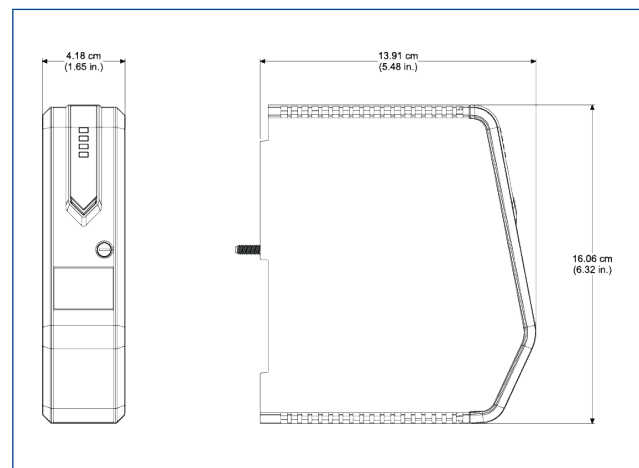

M-series VIM2 hardware dimensions.

Hardware Specifications

Specifications for the M-series Virtual I/O Module 2	
Power Requirement	Supplied by System Power Supply, either through the 4-wide vertical (only for simplex setups) or the 2-wide horizontal Power/Controller Carrier.
Maximum Current	1.4A at 5V DC
Fuse Protection (Internal)	3.0 A, non-replaceable fuses
Power Dissipation	5.0 W typical, 7.0 W maximum
User Memory	48 MB
Mounting	On right slot of power/controller carrier OR vertical carrier
Size Dimensions	4.1 cm W x 15.9 cm H x 10.7 cm D
Environmental Specifications	
Operating Temperature*	-40° to 60°C (-40° to 140°F)
Storage Temperature	-40° to 85° C (-40° to 185°F)
Relative Humidity	5 to 95%, non-condensing
Airborne Contaminants	ISA-S71.04-1985 Airborne Contaminants Class G3 Conformal coating
Shock (Normal Operating Conditions)	10 g ½-sine wave for 11 ms
Vibration (Operative Limit)	1 mm peak-to-peak from 5 Hz to 16 Hz, 0.5 g from 16 Hz to 150 Hz
LED Indicators – Running Status	
Green – Power	Indicates DC power is applied
Red – Error	Indicates an error condition
Green – Active	Indicates that the VIM2 is commissioned and active
Green – Standby	Indicates that the VIM2 is redundant and is in standby mode
Yellow – Network	Solid - Indicates valid network communication status
Yellow – Ctrl IO	Indicates valid DeltaV™ I/O Bus communication status
All except Power flashing, alternating even and odd	Visual ID of controller initiated from user interface software by ping command
External Connections	
Plant Ethernet Network	One 100BaseTX RJ-45 connectors (simplex mode only)
Plant Ethernet Network and Redundancy Link	One 100BaseTX RJ-45 connector (redundant mode) One 100BaseTX RJ-45 connector (cable supplied with redundant modules)

*Operating any electronics at the higher end of its temperature range for long periods of time will shorten its expected lifetime, see **Effects of Heat and Airflow Inside an Enclosure White Paper** for more information.

Software Specifications

Ethernet I/O Capacity	
Max VIM2 per DeltaV Controller	2
Max. Emulated DeltaV Cards	4 simplex cards in simplex setup 8 simplex cards in dual simplex setup 4 redundant pairs in redundant setup
Number of Network Devices	
Modbus TCP	96 in simplex setup / 192 in dual simplex setup 32 in redundant setup
Rockwell PLC Scanner	32 in simplex setup / 64 in dual simplex setup 16 in redundant setup
EtherNet/IP	128 in simplex setup / 256 in dual simplex setup 128 in redundant setup
Max IO Data	
Modbus TCP	<p>Programmable Serial Card datasets:</p> <ul style="list-style-type: none"> ■ 128 in simplex setup / 256 in dual simplex setup ■ 128 in redundant setup <p>A dataset can have up to 100 registers (50 for 32-bit or floating-point data).</p>
Rockwell PLC Scanner	<p>Programmable Serial Card datasets:</p> <ul style="list-style-type: none"> ■ 128 in simplex setup / 256 in dual simplex setup ■ 128 in redundant setup <p>A dataset can have up to 100 registers (50 for 32-bit or floating-point data).</p>
EtherNet/IP	<p>The VIM can emulate any mix of 4 Programmable Serial cards or DeviceNet cards. The card types selected determines the IO capacity.</p> <ul style="list-style-type: none"> ■ 32 datasets per emulated Programmable Serial card. A dataset can have up to 100 registers (50 for 32-bit or floating-point data). ■ Between 3,843 and 15,555 signals per emulated DeviceNet card, depending on signal data type. ■ A VIM cannot have more than 32,640 DeviceNet signals.

Certifications

The following certifications are available for M-series Virtual I/O Module 2:

- **CE**

EMC-EN 61326-1

- **FM**

FM 3600

FM 3611

- **CSA**

CSA C22.2 No. 213-M1987

CSA C22.2 No. 1010.1

- **ATEX**

EN60079-0

EN60079-7

- **IEC-Ex**

IEC60079-0

IEC60079-7

- **Marine Certifications** IACS E10

ABS Certificate of Design Assessment

DNV-GL Marine Certificate

Hazardous Area/Location

M-series Virtual I/O Module 2 can be installed and used based on the following Standards (see actual certificates for exact product markings for each product):

- **FM (USA)**

Class I, Division 2, Groups A, B, C, D, T4

- **cFM (Canada)**

Class I, Division 2, Groups A, B, C, D, T4

- **ATEX**

II 3G Ex ec IIC T4 Gc

- **IEC-Ex**

II 3G Ex ec IIC T4 Gc

Regarding the Installation instructions please refer to the following Documents:

Class 1 Division 2 Installation Instructions DeltaV™ M-series	12P1293
Zone 2 Installation Instructions DeltaV M-series	12P2046

Ordering Information

Description	Model Number
M-series Virtual I/O Module 2	VE4026
Redundant M-series Virtual I/O Modules (Includes two VIM2s and one redundancy link cable)	VE4027
Modbus TCP/IP Master Driver	IOD-4111
EtherNet/IP Scanner Driver	IOD-4112
ODVA EtherNet/IP Protocol Driver	IOD-4116

DeltaV Mimic is licensed on a Flexible Subscription Unit (FSU) basis. An FSU is a currency that can be used to access any Mimic feature licensed on an FSU basis, with each feature requiring its own number of FSUs. The FSU subscription is offered in one-year, three-year, and five-year terms. To purchase, extend, or expand a license, please contact your Emerson Sales Representative.

Related Products

- DeltaV Mimic
- Workstations and Servers for the DeltaV DCS
- DeltaV M-Series I/O Subsystem Horizontal Carriers
- DeltaV PK Controller
- DeltaV PK Flex Controller
- DeltaV MX Controller
- DeltaV MQ Controller

Prerequisites

- One power/controller carrier per VIM2. Please refer to the M-series Horizontal Carriers product data sheet for details.
- One dedicated system power supply per VIM2. Please refer to the M-series Power Supplies product data sheet for details.
- To use for I/O Simulation, DeltaV Mimic and DeltaV Railbus Driver features must be purchased.
- To use for Ethernet I/O integration, an Ethernet I/O driver must be purchased. Each operating VIM must be licensed independently (e.g., two licenses are required for a single redundant pair of VIMs). Technical support for the Ethernet I/O drivers is available.

System Compatibility

- M-series VIM can physically be replaced with M-series VIM2. However, the VIM2 is not a functional drop-in replacement for the VIM.
- Existing Drivers from M-series VIMs will not work with the M-series VIM2 and need to be converted before they can be reused.

©2026, Emerson. All rights reserved.

The Emerson logo is a trademark and service mark of Emerson Electric Co. The DeltaV logo is a mark of one of the Emerson family of companies. All other marks are the property of their respective owners.

The contents of this publication are presented for informational purposes only, and while diligent efforts were made to ensure their accuracy, they are not to be construed as warranties or guarantees, express or implied, regarding the products or services described herein or their use or applicability. All sales are governed by our terms and conditions, which are available on request. We reserve the right to modify or improve the designs or specifications of our products at any time without notice.

Contact Us

 www.emerson.com/contactus